



HYDRAULICS

**MAINTENANCE SET**  
**“CA0510” “CA1110” “CA2010” BASIC**  
**“CA0513” “CA1113” “CA2013” COMPLETE**



**Abdex Hydraulics - Victoria**  
27 Metcalf Street,  
Dandenong South, VIC. 3175  
**Tel:** (03) 9796 3744  
**Email:** sales@abdexhydraulics.com.au

**Abdex Hydraulics - Perth**  
260 Allen Road,  
Forrestdale, WA. 6112  
**Tel:** (08) 9418 4988  
**Email:** sales@abdexhydraulics.com.au

**Abdex Hydraulics - Queensland**  
8/315 Archerfield Road  
Richlands, QLD. 4077.  
**Tel:** (03) 9796 3744  
**Email:** sales@abdexhydraulics.com.au

**INDEX**

**1. BEFORE USING THE EQUIPMENT AND SECURITY----- 2**  
**2. TECHNICAL FEATURES AND COMPONENTS----- 2-3-4**  
**3. DECLARATION OF MANUFACTURER----- 5**  
**4. WARRANTY----- 5**

**ANNEX**

**❖ GENERAL DRAWING**

**1. BEFORE USING THE EQUIPMENT AND SECURITY.**

The CA equipment is used for repairing and maintenance operations. Their multiple choices of assembling trough different pieces make this equipment multi-user. All of CA maintenance sets are provided with a KC cylinder, a W pump and AZ20 hose. Choose the best equipment for the utility you need. The pull cylinder is provided under request in all the references. All the equipments are packed in a metallic box.

This equipment is supplied with different elements that mixed with the hydraulic tools: pump, cylinder and hoses; allows configuring specific tools for different operations as: pushing, separating, pulling, lifting, shrinking, stretching or fixing.

The models have a maximum capacity of push of 5, 10 and 20 ton, and two types: basic and complete.

In the complete set it is included a divider clamp and the specific tools to shrink.

The cylinder develops the nominal capacity expressed, but it has to be considerer that, with the accessories connected, the equipment must be only used in **50 % of its capacity; i.e., to maximum pressure of 350 bar.**

**2. TECHNICAL FEATURES AND COMPONENTS.**



N°	Description	CA0510	CA0513	CA1110	CA1113	CA2010	CA2013
1	Box	1	1	1	1	1	1
2	Pump	1	1	1	1	1	1
3	Hose	1	1	1	1	1	1
4	Male quick coupler	1	1	1	1	1	1
5	Cylinder	1	1	1	1	1	1
7	Stretching tube	1	1	1	1	-	-
8	Stretching tube	1	1	1	1	1	1
9	Stretching tube	1	1	1	1	1	1
10	Stretching tube	1	1	1	1	1	1
11	Cylinder collar	1	1	1	1	1	1
12	Piston collar	1	1	1	1	-	-
13	Fixing nut	3	3	3	3	3	3
14	Coupling sleeve	1	1	1	1	1	1
15	Head	1	1	1	1	2	2
16	Elastic head	2	2	2	2	-	-
17	Flat base	1	1	1	1	-	-
18	V-Base 90°	1	1	1	1	-	-
19	Wedge head	1	1	1	1	-	-
20	Adjustable elongation	1	1	1	1	-	-
21	Pin	2	2	2	2	-	-
22	Fixed Clamp	1	1	1	1	-	-
23	Sliding clamp	1	1	1	1	-	-
24	Spread Cylinder	-	1	-	1	-	1
25	Chain with hook	-	1	-	1	-	1
26	Support of the chain	-	1	-	1	-	1
27	Chain plate	-	1	-	1	-	1
28	Base	-	-	-	-	2	2
29	Pull cylinder	op	op	op	op	op	op



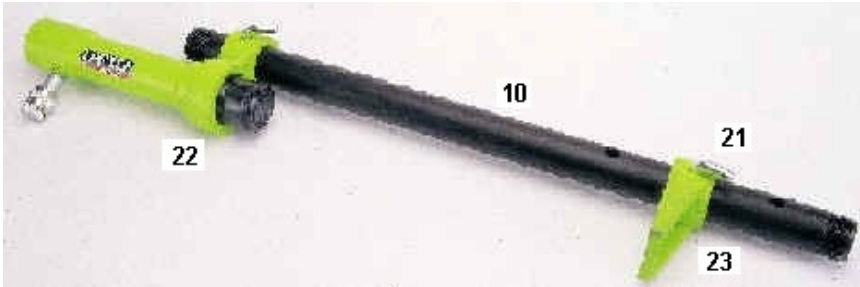
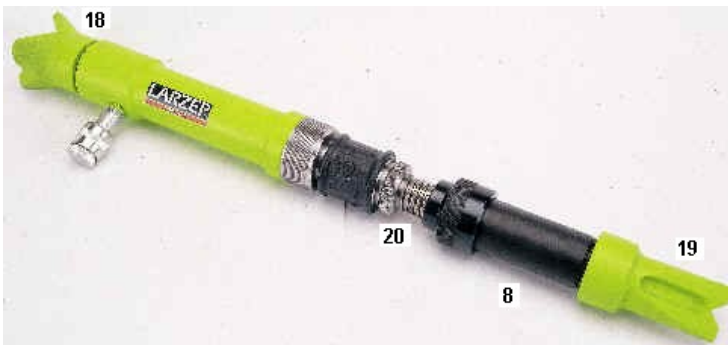
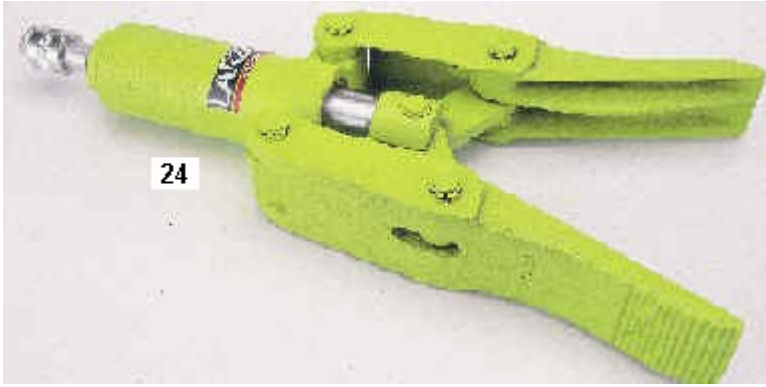

### **3. DECLARATION OF MANUFACTURER.**

LARZEP, S.A. located in Avda. Urtiaga 6, 48269 Mallabia (Vizcaya); declares that the maintenance sets are not a machine itself. Therefore, it will not be complete or safe, except in the cases that is assembled with the set of indicated accessories; as pump, cylinder and hose that corresponds by dimensions and force of work.

The components described in the chapter of technical features of this manual, are assembled by LARZEP, S.A., this equipment can't be put in use until it reunites the conditions necessary to be described as a complete and safe machine that it fulfils the requirements of the normative CE. In case that it is fulfilled, it will be able to take the noticeable CE.

Nevertheless, LARZEP, S.A. works in agreement to our standards of quality and under the control those norm ISO 9001 forces.

Signature:

D. Juan Carlos Bustos  
Quality Manager.

### **4. WARRANTY.**

**LARZEP, S.A.** guarantees its products against all design and manufacturing defects for the durations of two years from the date of purchase. This guarantee does not include the ordinary wear of both metal and non-metal parts, abuse, using the equipment beyond its rated capacity and any wear or damage incurred as a result of using a hydraulic fluid which is not recommended by **LARZEP, S.A.**

Please note that if the equipment is disassembled or serviced by anyone other than an authorized service dealer or by **LARZEP, S.A.**, this guarantee is rendered null and void.

In the event of a warranty claim, return the equipment, to **LARZEP, S.A.** or the authorized dealer which sold you the hydraulic equipment, **LARZEP, S.A.** will repair or replace the faulty equipment, whichever is deemed most appropriate. **LARZEP, S.A.** shall not be held liable for any consequential damages or losses, which may occur as a result of faulty equipment



MODELS: CA0510 Y CA0513

**CYLINDER**

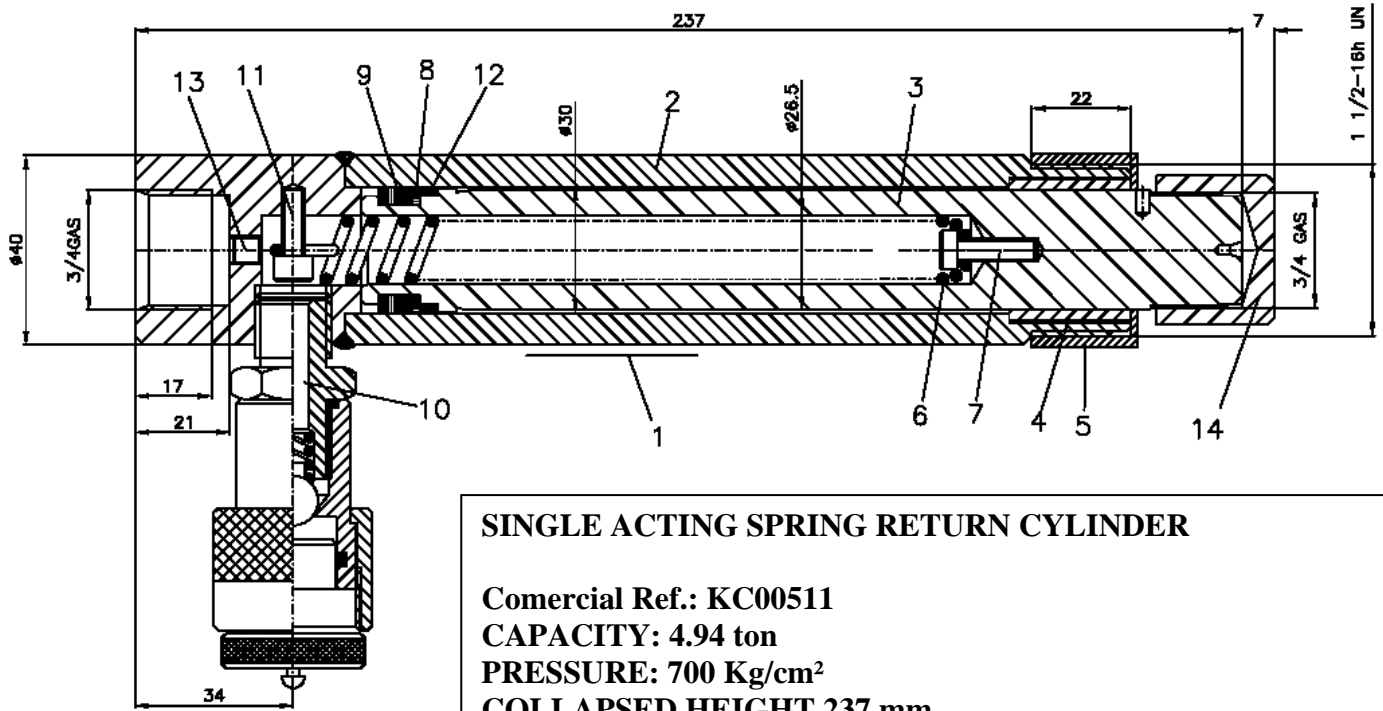

N	DESCRIPTION	CODE	Nº Pieces
1	LABEL	30 A0016	1
2	BODY	52H0001	1
3	PISTON	53H0001	1
4	GUIDE	55E0051	1
5	PROTECTOR	12L0001	1
6	SPRING	13 A0002	1
7	SCREW	14 A0003	1
8	SEGMENT	57 A0186	1
9	COLLAR Ø22xø30x4.4	12B0217	1
10	LOW FLOW FEMALE COUPLER	AZ3240	1
11	SCREW	14 A0002	1
12	BRONZED	58 A0285	1
13	PLUG 1/6 NPT	14F0006	1
14	DENTED KNOB	56H0001	

MODELS: CA0510, CA0513

**PUMP**

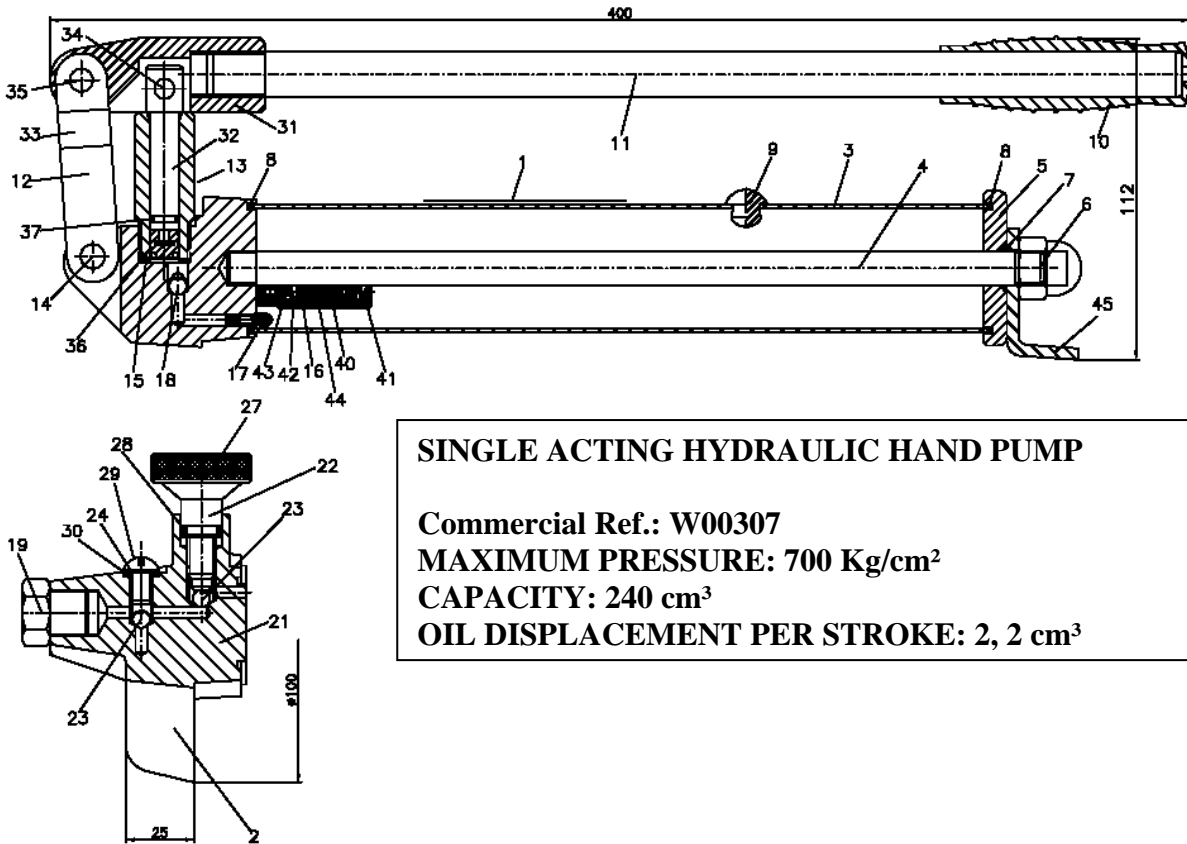

**SINGLE ACTING HYDRAULIC HAND PUMP**

**Commercial Ref.: W00307**  
**MAXIMUM PRESSURE: 700 Kg/cm<sup>2</sup>**  
**CAPACITY: 240 cm<sup>3</sup>**  
**OIL DISPLACEMENT PER STROKE: 2, 2 cm<sup>3</sup>**

N	DESCRIPTION	CODE	N° Pieces
1	LABEL	30 A0017	1
2	BASE SUBSET	50k0051	1
3	TANK	51B0017	1
4	TANK SHAFT	15I0273	1
5	TANK LID	15L0095	1
6	NUT M12	14B0004	1
7	O-RING AN9	12 A0048	1
8	SEALING RING OF THE TANK	57F0015	2
9	OIL PLUG	12C0026	1
10	HANDLE	24C0004	1
11	LEVER	24 A0005	1
12	LOAD INJECTOR	24J0030	1
13	SLEEVE	15D0002	1
14	RIVETING	15 A0014	1
15	WASHER	27 A0004	1
16	VALVE	17C0002	1
17	FILTER	13F0001	1
18	BALL Ø6	31 A0001	1
19	PLUG	AZ1182	1
20	CASE	21D0017	1
36	PISTON CAP	12J0001	1
37	PISTON SEAL Ø6.75x1.78	12 A0272	1
45	TANK LEG	24L0037	1

MODELS: CA0513, CA0510, CA1113, CA1110  
SPREAD CYLINDERS

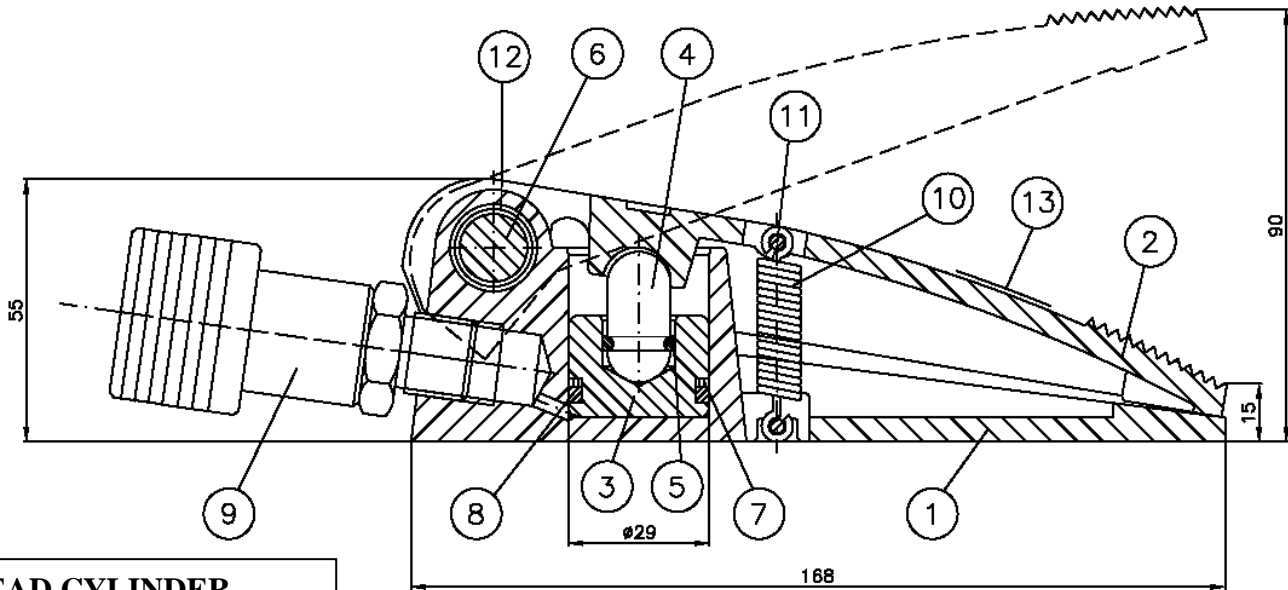

**SPREAD CYLINDER**

**Commercial Ref.: CY0109**  
**CAPACITY: 1 ton (9.81 kN)**  
**STROKE: 15mm**  
**AREA: 6.6 cm<sup>2</sup>**  
**OIL VOLUME: 10 cm<sup>3</sup>**  
**WEIGHT: 2 Kg**

N	DESCRIPTION	CODE	N Pieces
1	BASE	50H0004	1
2	JAW	24L0006	1
3	PISTON	53I0001	1
4	SADDLE	56P0001	1
* 5	O-RING Ø9.19x2.62	12A0047	1
6	SHAFT	15I0026	1
* 7	SEGMENT	57A0077	1
* 8	O-RING Ø 21.82x3.53	12A0090	1
9	COUPLER	AZ3240	1
10	SPRING	13A0031	1
11	PIN	15I0027	2
12	COLLAR	14D0005	1
13	LABEL	30A018	1

\* SPARE PART LIST

MODELS: CA1110 Y CA1113  
CYLINDER

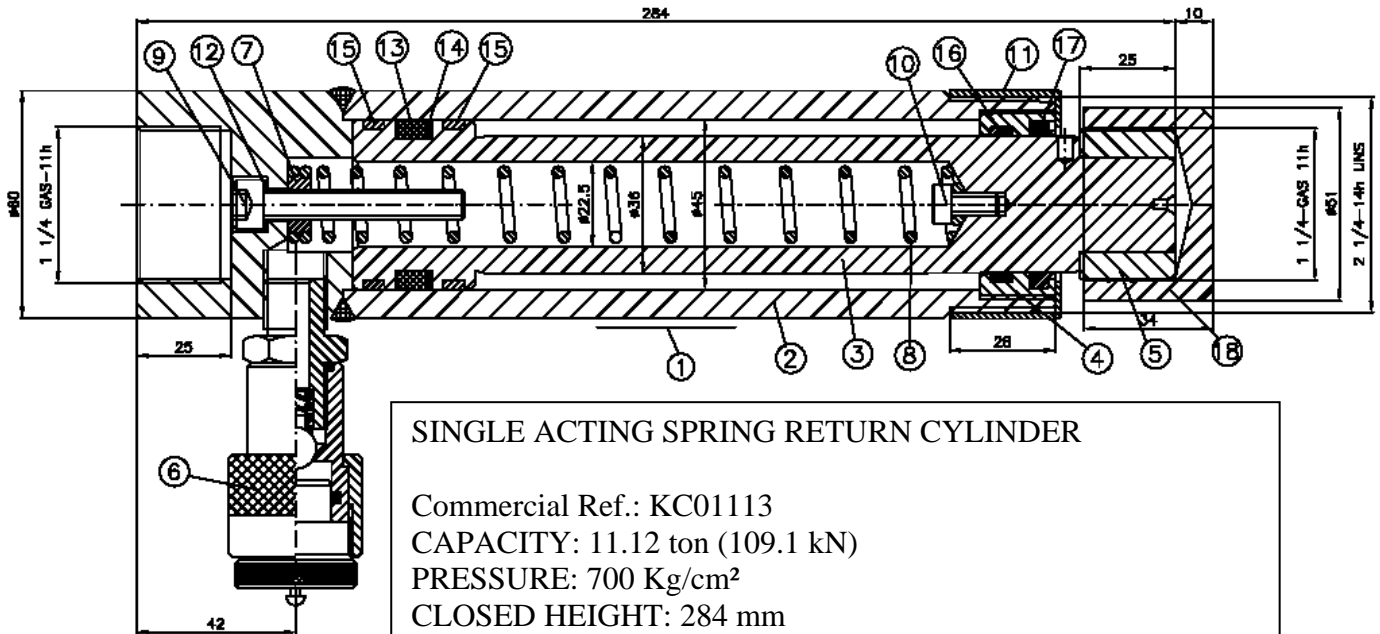

**SINGLE ACTING SPRING RETURN CYLINDER**

Commercial Ref.: KC01113  
CAPACITY: 11.12 ton (109.1 kN)  
PRESSURE: 700 Kg/cm<sup>2</sup>  
CLOSED HEIGHT: 284 mm  
STROKE: 133 mm  
AREA: 15.9 cm<sup>2</sup>  
OIL VOLUME: 214.7 cm<sup>3</sup>

N	DESCRIPTION	CODE	N Pieces
1	LABEL	30A0017	1
2	BODY	52H0007	1
3	PISTON	53H0012	1
4	GUIDE	55E0054	1
5	SADDLE	56H0008	1
6	LOW FLOW FEMALE COUPLER	AZ3240	1
7	SPRING TIE	24F0071	1
8	SPRING	13A0139	1
9	ALLEN SCREW M8x55 ALL THREAD	14A0117	1
10	ALLEN SCREW M6x10	14A0004	1
11	THREAD PROTECTOR	12L0002	1
12	CUPPER WASHER	57B0005	1
* 13	COLLAR Ø45x Ø 35x7.3	12B0199	1
* 14	SEGMENT	57A0052	1
* 15	GUIDE COLLAR Ø45x Ø 40x5.6	58F0136	2
* 16	GUIDE COLLAR Ø36x Ø41x5.6	58F0123	1
* 17	SCRAPER Ø36x Ø44x6	12H0063	1
18	DENTED KNOB	56H0003	1

**\* SPARE PART LIST**



MODELS: CA1110, CA1113, CA2010 Y CA2013.  
PUMP

**SINGLE ACTING HAND PUMP**

**Commercial Ref.:  
W00807  
CAPACITY 880 cm<sup>3</sup>  
PRESSURE: 700 Kg/cm<sup>2</sup>**

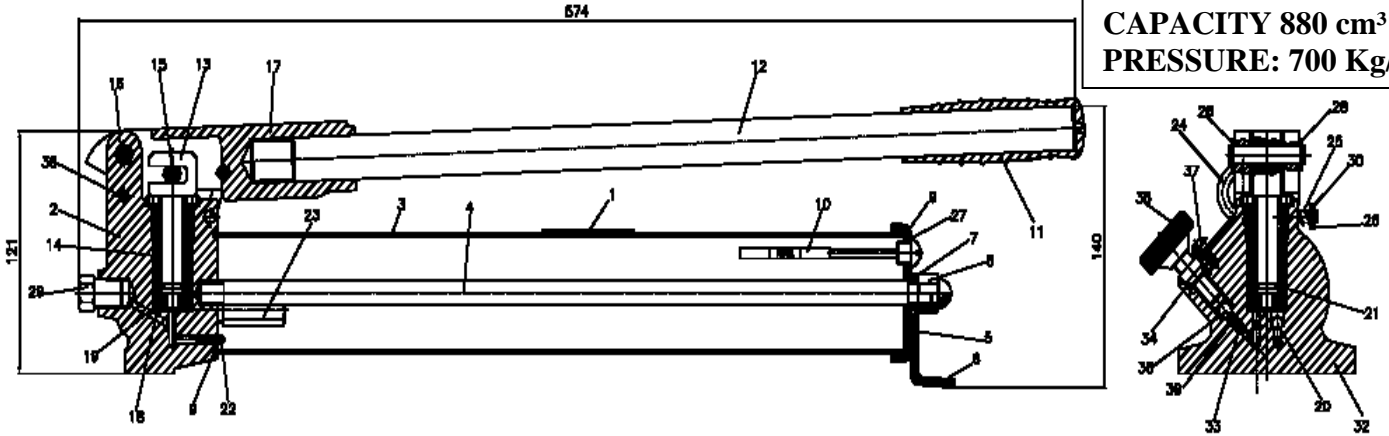

N	DESCRIPTION	CODE	N Pcs	N	DESCRIPTION	CODE	N Pcs
1	LABEL	30A0023	1	*21	O-RING AN7	12A0051	1
2	BASE SUBSET	50K0038	1	22	FILTER	13F0001	1
3	TANK	51B0042	1	23	750 Kg/cm <sup>2</sup> RATED VALVE	17C0003	1
4	TANK SHAFT	15I0003	1	24	TRANSPORT SHAFT	15I0159	1
5	TANK LID	32A0013	1	25	SPRING	13D0003	1
6	TANK LEG	24L0015	1	26	RETENTION WASHER	14D0042	1
7	ANSI O-RING	12A0048	1	27	O-RING	12A0051	1
8	CAP NUT	14B0004	1	28	SECURITY WASHER	14D0001	2
9	CLOSING COLLAR	57F0016	2	29	PLUG	15L0003	1
10	LEVEL PLUG SUBSET	15L0116	1	30	WASHER FOR M6	14C0004	1
11	HANDGRIP	24C0006	1	31	BOARD BOX	21D0019	1
12	LEVER	24A0007	1	<b>BASE SUBSET (PART2) SPARE PART LIST</b>			
13	PISTON	54C0004	1	32	BASE	50K0032	1
14	CASE	15D0023	1	33	BALL Ø4	31A0002	1
15	SHAFT	15I0007	1	34	O-RING AN8	12A0047	1
16	SHAFT	15I0008	1	35	DRIVE SCREW	15H0008	1
17	LEVER HANDLE	24B0026	1	36	PIN	14E0002	1
18	JOINT WASHER	57B0011	1	37	STOP SCREW	15L0022	1
*19	PISTON CUP	12J0004	1	38	BALL Ø6	31A0001	1
*20	BALL Ø6	31A0001	1	39	SPRING RETURN	13D0138	1

**\* SPARE PART LIST**

**MODELS: CA2010 Y CA2013  
CYLINDER**

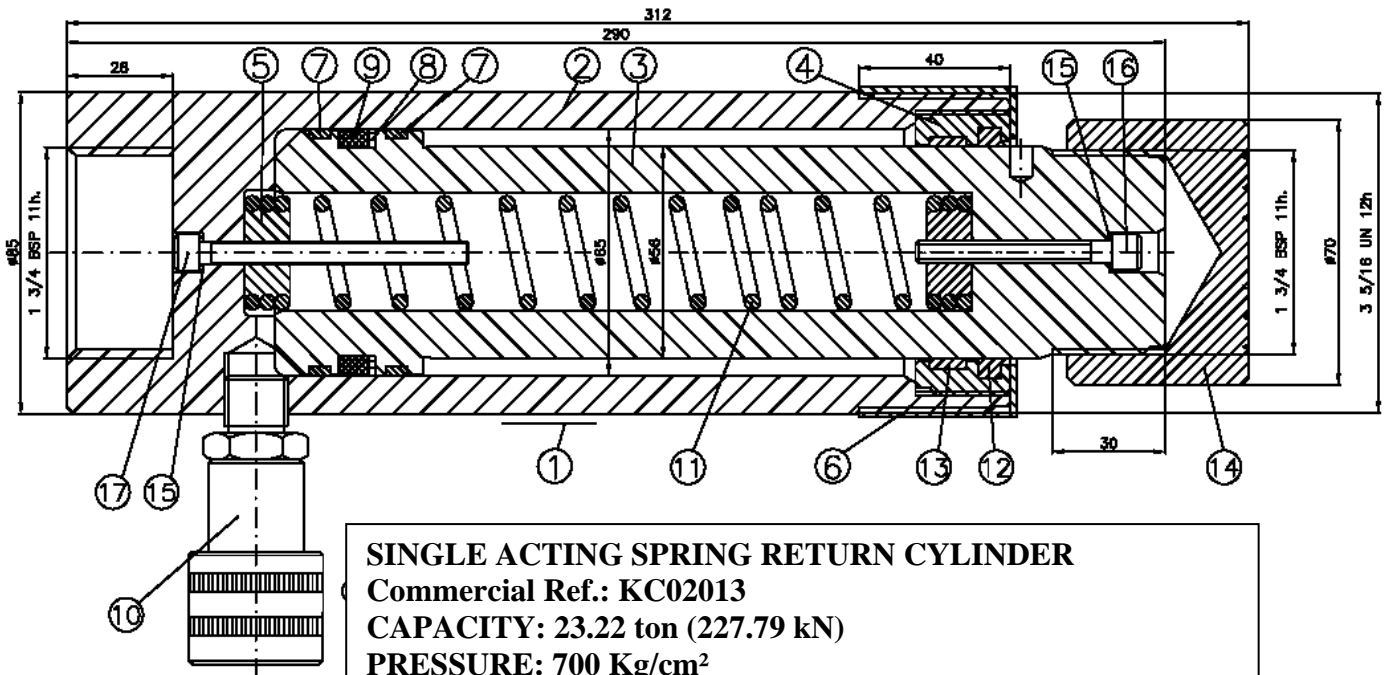

**SINGLE ACTING SPRING RETURN CYLINDER**

**Commercial Ref.: KC02013**  
**CAPACITY: 23.22 ton (227.79 kN)**  
**PRESSURE: 700 Kg/cm<sup>2</sup>**  
**CLOSED HEIGHT: 290 mm**  
**STROKE: 130 mm**  
**AREA: 33.18 cm<sup>3</sup>**  
**OIL VOLUME: 431.37 cm<sup>3</sup>**

N	DESCRIPTION	CODE	N Pieces
1	LABEL	30A0017	1
2	BODY	52E0186	1
3	PISTON	53H0011	1
4	GUIDE	55E0092	1
5	SPRING TIE	24F0087	2
6	PROTECTOR	12L0003	1
* 7	GUIDING COLLAR Ø60x Ø60x5.6	58F0112	2
* 8	SEGMENT	57A0019	1
* 9	COLLAR	12B0094	1
10	HIGH FLOW FEMALE COUPLER	AZ3240	1
11	SPRING	13A0220	1
* 12	SCRAPER ø56xø66x6	12H0071	1
* 13	GUIDING COLLAR ø56xø61x9.7	58F0135	1
14	DENTED KNOB	56H0005	1
15	CUPPER WAASHER	57B0001	2
16	ALLEN SCREW M6x50	14A0171	1
17	ALLEN SCREW M6x70	14A0125	1

\* SPARE PART LIST

**MODELS: CA2010 Y CA2013  
SPREAD CYLINDERS**

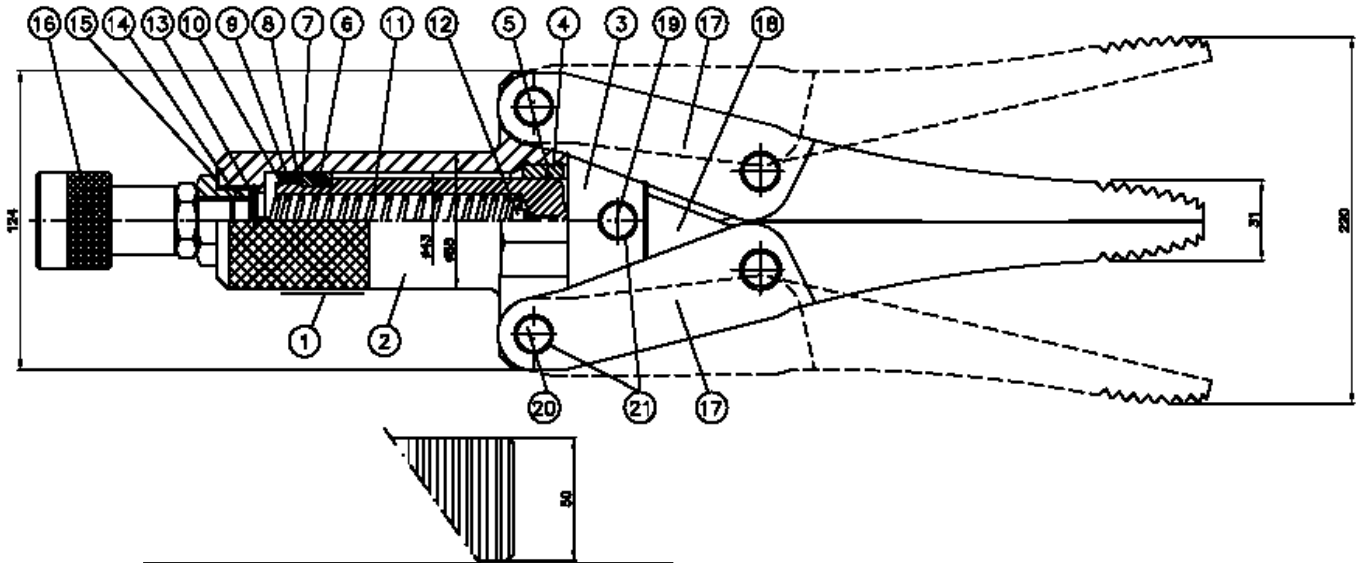

**SPREAD CYLINDER**

**Commercial Ref.: CY00822**  
**CAPACITY: 0.8 ton (7.848 kN)**  
**PRESSURE: 550 Kg/cm<sup>2</sup>**  
**CLOSED HEIGHT: 31 mm**  
**WEIGHT: 7 Kg**  
**STROKE: 53 mm**

N	DESCRIPTION	CODE	N Pieces
1	LABEL	30A0018	1
2	BODY	52I0001	1
3	PISTON	53I0002	1
4	GUIDE	55I0001	1
5	O-RING Ø37.82x1.78	12A0091	1
6	SECTOR COLLAR	58A0029	2
7	WASHER	57D0001	1
8	SEGMENT	57A0078	1
9	COLLAR Ø30x42x10	12B0029	1
10	COLLAR	14D0006	1
11	SPRING	13A0032	1
12	SCREW	14A0004	1
13	PIN	14E0012	1
14	NUT	15J0009	1
15	CUPPER WASHER	57B0010	1
16	COUPLER	AZ3240	1
17	JAWS	24L0007	2
18	TIES	24F0008	2
19	PIN	15I0028	1
20	PIN	15I0029	4
21	ELASTIC RING	14D0007	10