

## HYDRAULIC ELECTRIC PUMPS (MANUAL VALVE)



- ✓ Manual directional control valves.
- ✓ Also available HBE model, remote pendant controlled solenoid valves.
- ✓ The manual control valve is easily converted from double acting to single acting operation.
- ✓ Internal safety valve set at 700 bar to prevent overpressure.
- ✓ External adjustable pressure relief valve.
- ✓ For use with single acting or double acting cylinders for heavy lifting or production applications.
- ✓ Options: roll bars, glycerine pressure gauge and push button remote motor control.

NOTE: Pressure gauge is not included.

**AZ89**  
Hydraulic Oil



P.85

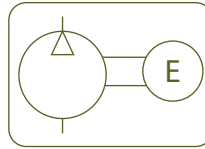

Type **HBM**

Capacity **5 - 25 litres**

Max. pressure **700 bar**

Capacity	A	B	C
l	mm	mm	mm
5	330	230	500
8,5	350	250	525
12,5	370	290	550
25	470	360	670

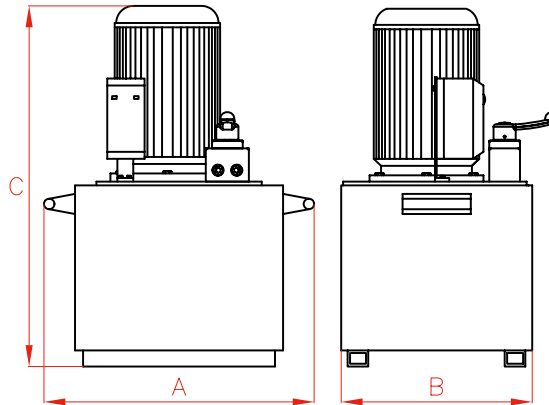

**ELECTRIC PUMPS (MANUAL VALVE)**

Tank Size	Flow 700 bar	Flow 50 bar	230V-1ph-50Hz	400V-3ph-50/60Hz	Motor Power	Pump Weight
			litres	l/min		
5	0,36	4,00	HBM7241	HBM7244	0,75	21
8,5	0,54	5,90	HBM3341	HBM3344	1,10	30
12,5	0,54	5,90	HBM3441	HBM3444	1,10	38
12,5	0,82	8,64	HBM4441	HBM4444	1,10	40
25	1,64	14,00	HBM5541	HBM5544	2,20	78
25	3,28	11,77	-	HBM6544	5,50	90

**PUMP OPTIONS** add letter behind pump model number



**B Remote Pendant**

- ✓ With 3 metre long cable.
- ✓ For remote operation of motor in HBM series, 'ON' button starts motor and stops when button is released.



**C Roll Bar**

- ✓ Protects pump and components: motor, valves, etc
- ✓ For easy portability.
- ✓ Different sizes available.



**G Glycerine Pressure Gauge**

- ✓ ± 1,6 % full scale
- ✓ Reliable pressure measurement.
- ✓ Pressure range: 0-1000 bar.