



HYDRAULICS

# HYDRAULIC BENDER “VZ1536”



**Abdex Hydraulics - Victoria**

27 Metcalf Street,  
Dandenong South, VIC. 3175

**Tel:** (03) 9796 3744

**Email:** sales@abdexhydraulics.com.au

**Abdex Hydraulics - Perth**

260 Allen Road,  
Forrestdale, WA. 6112

**Tel:** (08) 9418 4988

**Email:** sales@abdexhydraulics.com.au

**Abdex Hydraulics - Queensland**

8/315 Archerfield Road  
Richlands, QLD. 4077.

**Tel:** (03) 9796 3744

**Email:** sales@abdexhydraulics.com.au

**INDEX**

**1. BEFORE USING THE EQUIPMENT AND SECURITY ..... 2**  
**2. TECHNICAL FEATURES .....2-3**  
**3. START UP ..... 3**  
**4. MAINTENANCE ..... 4**  
**5. PROBLEMS, DAMAGES AND SOLUTIONS ..... 4**  
**6. WARRANTY ..... 4**  
**7. DECLARATION OF CONFORMITY ..... 5**

**ANNEX**

❖ **GENERAL DRAWING**

**1. BEFORE USING THE EQUIPMENT AND SECURITY.**

LARZEP hydraulic benders are designed in accordance with internal quality standards, in compliance with the ISO 9001 regulation. If you find any damage or fault with the product, clearly label it and place it in a location where it will not be available for use until an authorized service dealer has repair the fault.



**Never use hydraulic equipment that is damaged or suspected to be in poor conditions.**

The tools are designed for the applications described in this manual. Any other use may pose a risk to the equipment and result in hazardous situations for the operator. The manufacturer accepts no responsibility for damage resulting from the improper use of the tool.



**Do no store or leave the hydraulic bender where is can be accessed by the children.**



The operator should be fully aware of the risks inherent in the use of high-pressure hydraulic tools, and should act responsibility in accordance with that described in this manual, ensuring both his/her own safety as well as the safety of others located in the vicinity of the working zone.



Boots



Helmet



Glasses



Gloves



Clothes

Never modify the tool or add elements that may affect its safety, without express authorisation from the manufacturer.

Before using, check for:

- 1- There are not operators standing around dangerous area.
- 2- Ensure that the equipment it's located over firm ground.
- 3- Do not work around dangerous area.
- 4- The commands have been operated with the hands.
- 5- Damaged or dirtied connections or coupler.
- 6- The flexible hydraulic hoses are not twisted.
- 7- The commands are in neutral position.



Check that the working pressure is less than the 80% of nominal capacity

Specialist personnel should only carry out repairs and maintenance operations, etc. Always use original LARZEP spare parts.

Carry out maintenance operations on a regular basis, as indicated in this manual.

Once you have finished using the tool, disconnect it, clean it and store it in a clean, safe place.

**2. TECHNICAL FEATURES.**

The supplied benders in standard equipments are the ones indicated in the enclosed board below. The obtained radius bending the tube 90° (long radius benders) is also included.

TUBE	INCHES	1/2"	3/4"	1"	1 1/4"	1 1/2"	2"	2 1/2"	3"
	DIAMETER (mm)	21	27	34	42	48	60	75	88
RADIUS		40	60	80	100	115	165	245	290
ANGLE		90	90	90	90	90	90	90	90

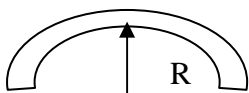

All the models include not only a complete bender seal kit in order to fit them in the piston but also two bending rollers with their corresponding grooves to fit in the tube.

They also include the structure with the upper and lower and also the axles corresponding to the bending rollers.

<b>MODEL</b>	<b>VZ1535</b>
<b>DESCRIPTION</b>	Bender ½"-3" with hydro pneumatic pump.
<b>CYLINDER</b>	Single acting. Return by spring. Ref.: SM01535
<b>CAPACITY</b>	16 ton 700 Kg./cm <sup>2</sup>
<b>STROKE</b>	355 mm.
<b>PUMP</b>	Hydro pneumatic pump "Z12107"
<b>TANK CAPACITY</b>	2,1 Litres
<b>POWER</b>	700 Bar
<b>WEIGHT</b>	169 Kg.

### 3. START UP.

The bender is packed in a sturdy wooden box, which protects it from the knock damage throughout the transportation. Once the tool is used, clean it and keep it into the box, to be stored until next usage.

Unpack the equipment assuring that all the parts indicated in the drawing provided in the manual are found and the material has not been damaged.

The hydraulic part is provided threaded to the structure plate of the grounds. Mount in this plate the lower and upper grounds. (Stick with the tube measures up faced) with the axles and clips. Checking that the upper ground tilts free.

<b>MODEL VZ1535</b>	
1-	Connect the air hoses (coupler ¼"NPT) with the air port and the oil port (coupler 3/8" NPT) of the pump with the cylinder making sure the perfect connection, unscrew the purge screw of the pump 3 or 4 turns.
2-	Make the connection of the air, the pump needs an air pressure of 2,8 : 10 Bar and a maximum flow of 0,8 L/min.
3-	Make sure that the working area is free and all the elements perfectly located.
4-	Put the feet in the pedal of the pump.
5-	Push with the feet the position "Pump" of the pedal, the oil is pumped to the circuit and the cylinder is pressurized.
6-	In order to maintain the pressure, release the pump and let it in a central position.
7-	In order to return the oil of the cylinder by its internal spring, and depressurize the equipment, push the "Release" position.

#### **BENDING**

Once we know the tube to bend dimensions, act in the following way:

1. Lift the upper ground up to the vertical. (1)
2. Put the axles in the holes corresponding to the measure of the tube and indicated in the sticker.
3. Put the rollers in the axles in the position corresponding to the tube to bend. See the marks in the rollers.
4. Put the bender corresponding to the tube in the prominent part of the piston.
5. Close the upper ground fitting all the parts.
6. Introduce the tube to bend by a lateral side, between both of the grounds taking care of not turning the rollers from their correct position and maintaining the bender in the piston top (2).
7. Act over the hydraulic part according to what is described in the previous point.
8. Make the piston go outside only the necessary to get the required bending angle, taking into account the elasticity of the tube. (3)
9. Take away pressure from the hydraulic part. The piston will return and it will let the tube free. Lift the ground and remove the tube. Normally the bender could be pressing the tube. Use the plastic hammer to separate it. (4)

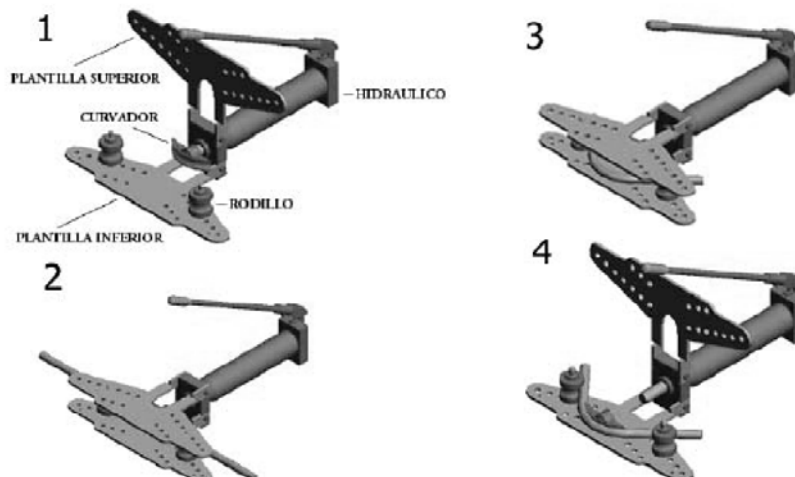

**Instruction Manual**  
**Hydraulic Bender “VZ1536”**

**4. MAINTENANCE.**

1. Make sure that the machine is switched off and not under pressure before carrying out any maintenance operation.
2. Use always original LARZEP S.A. parts.
3. Check always the equipment visually before using, check the oil level, damage in the hydraulic element (scratched piston, threads, leaks, etc.), accessories situation (hose, rapid coupling, etc.).
4. After using, clean always the equipment and keep the friction areas greased, such as: threads, axis, rollers inside, piston, etc. before keeping in the case.
5. In case of severe usage, substitute periodically the hoses and the couplings, although they do not seem damaged at first sight.
6. Periodically (minimum once a year), substitute the tank oil by clean oil. Use always LARZEP S.A. oil.
7. Reparation or maintenance actions, in which the mechanic parts must be dismantled (jack, cylinder o pump), will be carried out by specialized staff.

<b>MODEL</b>	<b>VZ1535</b>
<b>OIL FILLING</b> (Each 250 hours of using, and unless once a year)	By means of the filling plug, check the level and use hydraulic oil such as: MOBIL DTE 11, SHELL TELLUS OIL T15, CASTROL HYPSPIN AWH15

**5. PROBLEMS, DAMAGES AND SOLUTIONS.**

<b>MODEL VZ1226</b>		
<b>PROBLEM</b>	<b>POSSIBLE DAMAGE</b>	<b>SOLUCIÓN</b>
1- The piston does not advance.	- Excess or lack of oil.	1. Check the level and refill.
	- Obstructed filter.	2. Release the pump and clean.
	- The cylinder’s seal damaged	<b>3. Go to authorized service dealer.</b>
	- Bad air connection.	4. Check the air connection.
	- Bad hose connection.	5. Check the connection.
2- The cylinder does not pressurize.	- The cylinder’s seal damaged	<b>6. Go to authorized service dealer.</b>
	- Internal security valve damaged.	<b>7. Go to authorized service dealer.</b>
	- Air pressure very lower.	8. Check the pressure of the air port (it must be between 2,8 and 10 bar)
3- The piston do not retracts.	- Ball of the acting screw.	<b>9. Release the screw and move the ball.</b>
	- Grippped or damaged piston.	<b>10. Repair or replace the piston.</b>
	- Cylinder’s spring damaged.	<b>11. Replace the spring.</b>

The solutions in black, must be carried out by specialist personnel only.

**6. WARRANTY.**

**LARZEP, S.A.** guarantees its products against all design and manufacturing defects for the durations of two years from the date of purchase. This guarantee does not include the ordinary wear of both metal and non-metal parts, abuse, using the equipment beyond its rated capacity and any wear or damage incurred as a result of using a hydraulic fluid which is not recommended by **LARZEP, S.A.**

Please note that if the equipment is disassembled or serviced by anyone other than an authorized service dealer or by **LARZEP, S.A.**, this guarantee is rendered null and void.

In the event of a warranty claim, return the equipment, to **LARZEP, S.A.** or the authorized dealer which sold you the hydraulic equipment, **LARZEP, S.A.** will repair or replace the faulty equipment, whichever is deemed most appropriate. **LARZEP, S.A.** shall not be held liable for any consequential damages or losses, which may occur as a result of faulty equipment

**7. DECLARATION OF CONFORMITY.**

**DECLARACION DE CONFORMIDAD**

LARZEP, S.A.  
Dirección: Avda. Urtiaga, 6  
48269 Mallabia ESPAÑA

Declaramos bajo nuestra exclusiva responsabilidad la conformidad de los productos a los que refiere esta declaración, con las disposiciones de la directiva:  
89/392/CEE, 91/368/CEE, 93/44/CEE, 93/68/CEE, 98/37/CEE

**E**

**DECLARATION OF CONFORMITE**

Nous, LARZEP, S.A.  
Adresse: Avda. Urtiaga, 6  
48269 Mallabia SPAIN

Déclarons sous notre seule responsabilité que les produits auxquels se réfère cette déclaration sont conformes aux dispositions des Directives:  
89/392/EEC, 91/368/EEC, 93/44/EEC, 93/68/EEC, 98/37/EEC

**F**

**DECLARAÇÃO DE CONFORMIDADE**

Nós, LARZEP, S.A.  
Endereço: Avda. Urtiaga, 6  
48269 Mallabia SPAIN

Declaramos, sob nossa única responsabilidade, que os seguintes produtos, incluídos nesta declaração estão em conformidade com o disposto na Directiva:  
89/392/EEC, 91/368/EEC, 93/44/EEC, 93/68/EEC, 98/37/EEC

**P**

**ÖVERENSSTEMMELSESERKLÆRING**

Vi, LARZEP, S.A.  
Adresse: Avda. Urtiaga, 6  
48269 Mallabia SPAIN

Erklærer på eget ansvar, at følgende produkter som er omfattet af denne erklæring, er i overensstemmelse med bestemmelsene i Direktiv:  
89/392/EEC, 91/368/EEC, 93/44/EEC, 93/68/EEC, 98/37/EEC

**DK**

**ERKLÆRINGOM OVERENSSTEMMELSE**

Vi, LARZEP, S.A.  
Adresse: Avda. Urtiaga, 6  
48269 Mallabia SPAIN

Erklærer på eget ansvar, at følgende produkter som dekkes av denne erklæringen, er i overensstemmelse med bestemmelsene i Direktiv:  
89/392/EEC, 91/368/EEC, 93/44/EEC, 93/68/EEC, 98/37/EEC

**N**

**ÜBEREINSTIMMUNGSERKLÄRUNG**

Wir, LARZEP, S.A.  
Anschriřt: Avda. Urtiaga, 6  
48269 Mallabia SPAIN

Erklären aufeigene Verantwortung, , daß folgende Produkte, auf die sich diese Erklärung bezieht, mit den Bedingungen der Direktiven 89/392/EEC, 91/368/EEC, 93/44/EEC, 93/68/EEC, 98/37/EEC übereinstimmen.

**D**

Tipo, Type, Typ, Tyyppe.

**SM / SH / SP / SMP / SX / SMX / ST / STX / SL / SMA / SHA / SSR / T / TE / TD / D / DH /  
DDR / Z / ZR / W / X / YA / YG / YZ / HM / HE / HG / HZ / HS / WI / CK / CC / CN / FU / FV  
/ FZ / FA / CY / AA / AU / CT / C / KC**

**A / AB / AC / BL / B / AF / F / HN / DLG / DL / DP / VA / VB / VC / VZ / EC / EE / EG / EM /  
EZ / CA / CS**

Mallabia, ESPAÑA 2005 / 04 / 27

Lugar y fecha, place and date, lieu et date, plats och datum, paikka ja päivämäärä, udstedelsessted og-dato, ort und datum, plaats en datum, local e data, luogo e data.

**DECLARATION OF CONFORMITY**

We, LARZEP, S.A.  
Address: Avda. Urtiaga, 6  
48269 Mallabia SPAIN

Declare under our sole responsibility that the following products to which this declaration relates conform with the provisions of Directives:  
89/392/EEC, 91/368/EEC, 93/44/EEC, 93/68/EEC, 98/37/EEC

**GB**

**DICHIARAZIONE DI CONFORMITÀ**

Noi, LARZEP, S.A.  
Indirizzo: Avda. Urtiaga, 6  
48269 Mallabia SPAIN

Dichiariamo sotto la nostra esclusiva responsabilità che i prodotti ai quali questa dichiarazione si riferisce sono conformi quanto previsto dalle Direttive:  
89/392/EEC, 91/368/EEC, 93/44/EEC, 93/68/EEC, 98/37/EEC

**I**

**VAATIMUSTEMUKAISUUSVAKUUTUS.**

Me, LARZEP, S.A.  
Osoite: Avda. Urtiaga, 6  
48269 Mallabia SPAIN

Vakuutamme yksinomaan omalla vastuullamme, että seuraavat tuotteet, joihin tämä vakuutus liittyy, ovat seuraavien Direktiivien vaatimusten mukaisia:  
89/392/EEC, 91/368/EEC, 93/44/EEC, 93/68/EEC, 98/37/EEC

**FIN**

**VERKLARINGVAN OVEREENKOMST.**

Wij, LARZEP, S.A.  
Adres: Avda. Urtiaga, 6  
48269 Mallabia SPAIN

Verklaren geheel onder eigen verantwoordelijkheid dat de volgende producten, waarop deze verklaring heeft in overeenstemming zijn met de bepalingen van Richtlijn:  
89/392/EEC, 91/368/EEC, 93/44/EEC, 93/68/EEC, 98/37/EEC

**NL**

**FÖRSÄKRAN OM ÖVERESSTÄMMELSE**

Vi, LARZEP, S.A.  
Adress: Avda. Urtiaga, 6  
48269 Mallabia SPAIN

Försäkrar under eget ansvar att följande produkter som omfattas av denna försäkran är i överensstämmelse med villkoren i Direktiv:  
89/392/EEC, 91/368/EEC, 93/44/EEC, 93/68/EEC, 98/37/EEC

**S**

**LARZEP, S.A.**

Nombre y firma, name and signature, nom et signature, namn och underskrift, nimi ja nimikirjoitus, navn og underskrift, name und underskrift, naam en handtekening, nome e assinatura, nome e firma.

**Instruction Manual**  
**Hydraulic Bender "VZ1536"**

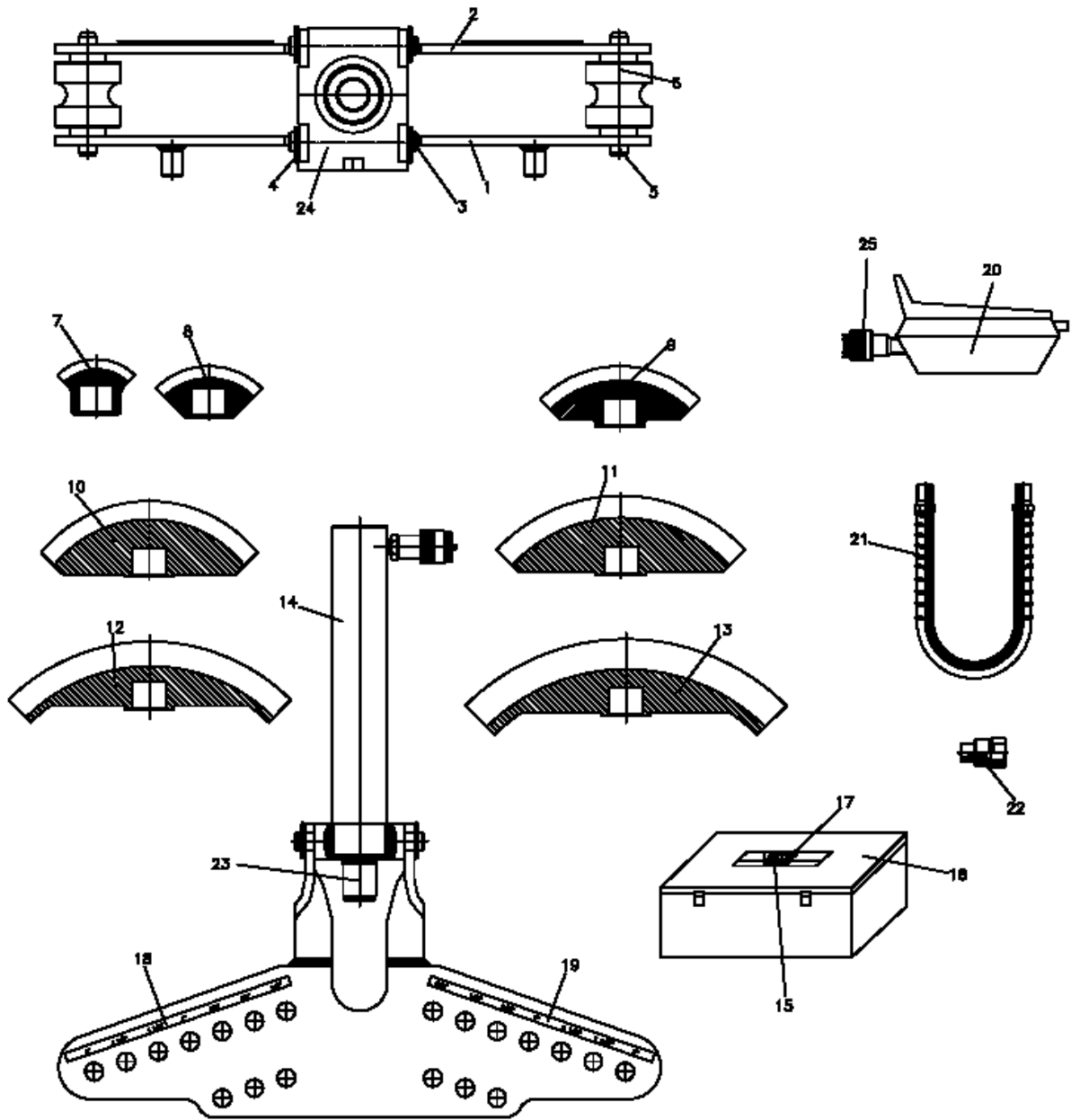

N	DESCRIPTION	CODE	N PIECES
1	LOWER BENDING SHOES	24 K0037	1
2	UPPER BENDING SHOES	24 K 0038	1
3	SHAFT	15 I0135	2
4	PIN "R" CLIPS	14 E0017	4
5	SHAFT	15 I0032	2
6	ROLLER	24 M0001	2
7	BENDER 3/8"	24 K0009	1
8	BENDER 1/2"	24 K0010	1
9	BENDER 3/4"	24K0011	1
10	BENDER 1"	24K0012	1
11	BENDER 1 1/4"	24K0013	1
12	BENDER 1 1/2"	24K0014	1

N	DESCRIPTION	CODE	N PIECES
13	BENDER 2"	24 K0015	1
14	CYLINDER	SM01535	1
15	LABEL	30 A0086	1
16	WOODEN BOX	CU2000	1
17	LABEL	30 A0021	1
18	LEFT LABEL	30 A0030	1
19	RIGHT LABEL	30 A0031	1
20	AIR PUMP	Z12107	1
21	HOSE	AP2015	1
22	MALE COUPLER	AZ3120	2
23	SADDLE	56 E0076	1
24	TEMPLATTE	24 K0308	1
25	COUPLER	AZ3140	1

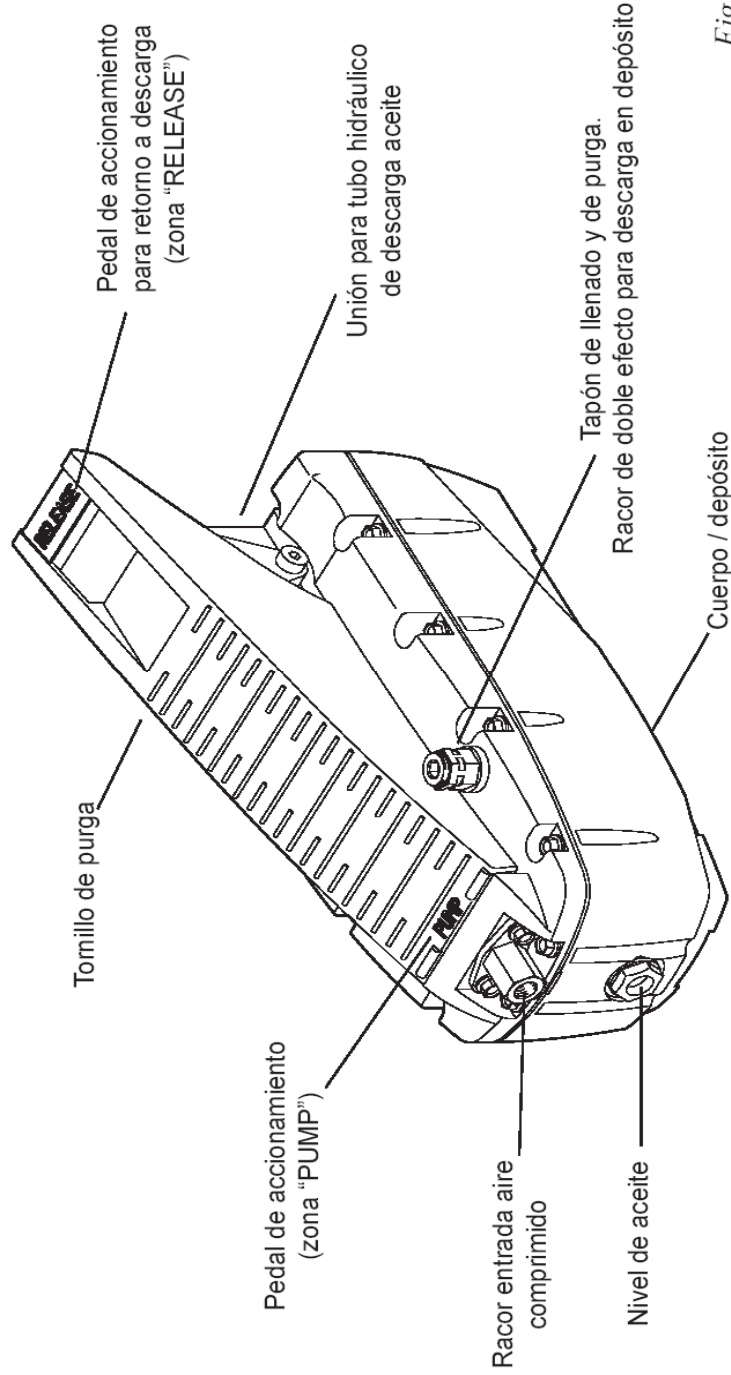

*Fig. 11*