

**PETROL HYDRAULIC PUMPS**

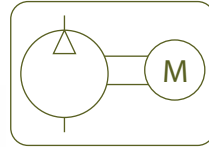

**PETROL HYDRAULIC PUMPS**



Type

**HAG**

Capacity

**14 - 50 litres**

Max. pressure

**700 bar**

HAG PUMPS

- ✓ Powered by a gasoline engine. For operation in remote locations where electric supply is not available.
- ✓ The manual control valve is easily converted from double acting to single acting operation.
- ✓ Internal safety valve set at 700 bar to prevent overpressure.
- ✓ External adjustable pressure relief valve.
- ✓ Roll bar and wheel kits available as options on request.

Capacity	A	B	C
l	mm	mm	mm
14	368	290	665
25	450	325	760
50	540	415	860

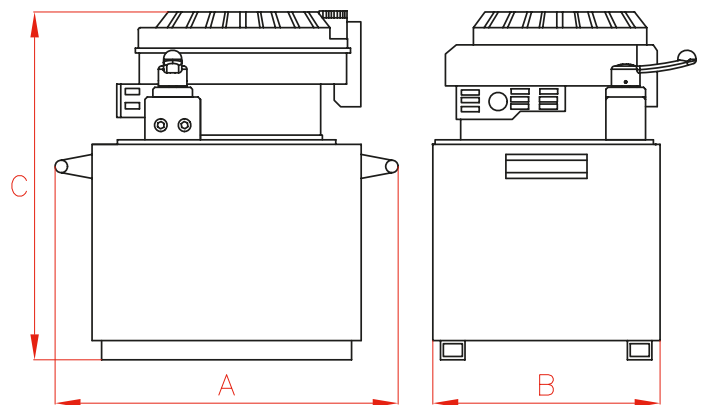

Tank	Flow at 700 bar	Flow at 60 bar	Valve Function	Single/A	Double/A	Power	Weight
I	l/min	l/min				kW	kg
14	0,36	4	Advance-Hold-Retract	HAG742	HAG744	3,6	36
25	0,36	4	Advance-Hold-Retract	HAG752	HAG754	3,6	60
50	0,36	4	Advance-Hold-Retract	HAG762	HAG764	3,6	93