

M200-90



Victoria

A: 27 Metcalf Street, Dandenong South, Victoria, 3175

P: (03) 9796 3744

Western Australia

A: 260 Allen Road Forrestdale, Western Australia, 6112

P: (08) 9418 4988

Queensland

A: Unit 8, 315 Archerfield Road, Richlands, Queensland, 4077

P: (03) 9796 3744

New South Wales

A: Unit D, 26 Penny Place, Arndell Park, New South Wales, 2148

P: (03) 9796 3744



E: sales@abdexhydraulics.com.au

M200-90

Mammut Air / Hydraulic heavy vehicle jacks are engineered and manufactured to offer all customers a lifting solution that is reliable, safe and easy to use.

M200-90



- Lightweight, quiet, compact and easy to manoeuvre.
- Remote control as standard for extra safety.
- Folding handle.
- Wide range of models and capacities from 60 t to 200 L
- Designed for tough Australian conditions
- Pneumatic tyres for easy operation.
- Internal check valves to prevent unintentional descent.
- Load blocks are available for mechanical lock and to turn jack into a jack stand.

Capacity:	200 t / 220.4 ton
Net Weight:	450 kg / 992 lb
Working Air Pressure:	10-12 bar / 145 - 174 psi
Air Consumption:	600 nl/min
Min. Height:	900 mm / 35.4 in
Max. Height:	1,450 mm / 57 in
Number of Pistons:	1
Pistons Stroke:	550 mm / 21.6 in

Accessories



M4935

Extension Holder Right

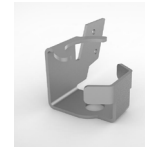

M4936

Extension Holder Left



M4930

Extension 200 mm



M4931

Extension 250 mm



M4932

Extension 300 mm

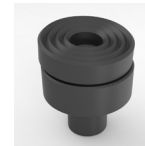

A04495

Tilt Saddle



LBS200-90

Load block set

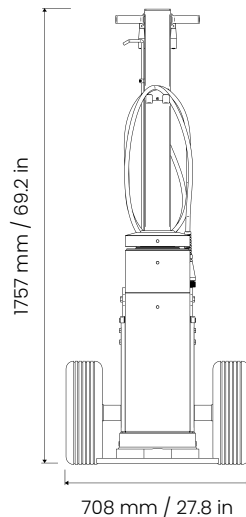
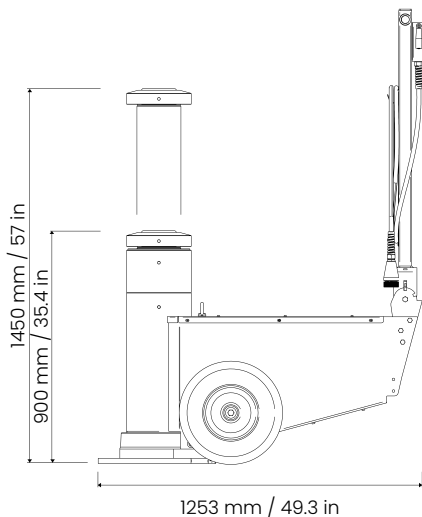

sales@abdexhydraulics.com.au



www.mammut.com.au