

CGS#D / CGS#T

CYLINDERS / LOAD RETURN

TELESCOPIC DOUBLE OR TRIPLE STROKE

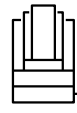

● FORCE	5 - 50 t
● STROKE	100 - 300 mm
● MAX WORKING PRESSURE	700 bar

FEATURES

The hydraulic telescopic cylinders **CGS** are an efficient solution when you have very little space available below the load and when a long stroke is required. They can be manufactured with double stroke (D) or with triple stroke (T). Given the high expansion only the 3% of maximum side load is allowed.

OPERATIONAL AREAS

This type of cylinder has various applications, especially in lifting of machineries but it's considered very handy in areas with restricted space.

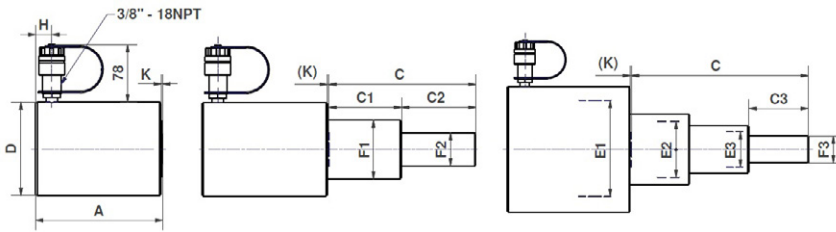

SELECTION CHART

Cylinders with non standard force and stroke can be supplied upon request.

PUSHING FORCE			TOTAL STROKE	STROKE			OIL VOLUME	MODEL	CLOSED HEIGHT		Ø PISTON			Ø RODS			ROD PROJECTION	COUPLER HEIGHT	WEIGHT
1° Stroke	2° Stroke	3° Stroke		1° Stroke	2° Stroke	3° Stroke			A	D	1°	2°	3°	1°	2°	3°			
t* kN	t* kN	t* kN	C mm	C1 mm	C2 mm	C3 mm	cm³		A mm	D mm	E1 mm	E2 mm	E3 mm	F1 mm	F2 mm	F3 mm	K mm	H mm	kg
50 496	20 198	5 49,5	280	100	100	80	1045	CGS5T280	173	127	95	60	30	80	50	24	2	22	14
30 309	10 111	-	100	50	50	-	370	CGS10D100	111	102	75	62	-	45	35	-	1	19	6.5
100 929	30 309	10 111	300	100	100	100	1925	CGS10T300	191	175	130	75	45	100	62	35	2	22	30
30 309	15 137,5	-	300	150	150	-	955	CGS15D300	220	102	75	50	-	65	40	-	1	19	13
50 496	20 198	-	100	50	50	-	495	CGS20D100	122	127	95	60	-	80	45	-	1	22	11
50 496	20 198	-	200	100	100	-	990	CGS20D200	173	127	95	60	-	80	45	-	2	22	15
150 1407	50 496	20 198	300	100	100	100	3000	CGS20T300	212	213	160	95	60	120	80	45	3	30	49
100 929	30 309	-	200	100	100	-	1768	CGS30D200	190	175	130	75	-	100	55	-	1	22	30
75 727	30 309	-	300	150	150	-	2225	CGS30D300	271	155	115	75	-	100	60	-	2	28	36
150 1407	50 496	-	200	100	100	-	2718	CGS50D200	211	213	160	95	-	120	80	-	2	30	50
150 1407	50 496	-	300	150	150	-	4075	CGS50D300	261	213	160	95	-	120	80	-	2	30	59

* Nominal value, see kN for the exact force.

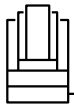

● FORCE	5 - 50 t
● STROKE	100 - 300 mm
MAX WORKING PRESSURE	700 bar

CGS#D / CGS#T

CYLINDERS / LOAD RETURN

TELESCOPIC DOUBLE OR TRIPLE STROKE

ACCESSORIES ZTT TILT SADDLES



They can **ONLY** be used up to the maximum pushing force of the last stroke.

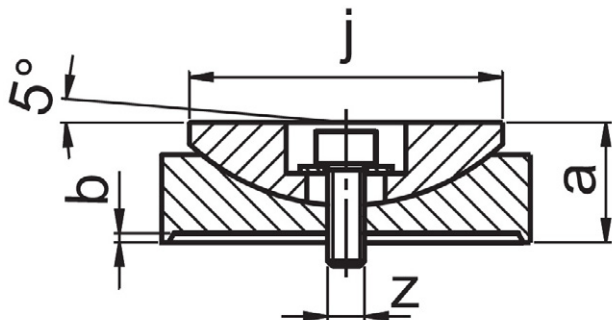

MODEL	For use with	a	b	j	z	kg
ZTT10	CGS10 # # # #	16	1	34	M4	0.1
ZTT20	CGS20 # # # #	18		43	M5	0.2
ZTT30	CGS30 # # # #	19		53		0.3
ZTT50	CGS50 # # # #	25		68	M8	0.9

MODEL CODING

CGS	10	D	###
Series	Pushing Force in t	D = double stroke T = triple stroke	Stroke in mm



It's important to drop the pressure inside the cylinder before disconnecting the quick coupler to avoid problems re-inserting or if lowering the load. In case some pressure persists it is possible to use the apposite tool **KST38** in order to lower the pressure in the couplers.