

# CMI#N / CMI#W

## MULTI-PURPOSE CYLINDERS

### SPRING RETURN WITH IMPERIAL THREAD

#### FEATURES

All the CMI cylinders have collar threads on the cylinder body and mounting holes in the base. They are supplied with an interchangeable grooved pushing saddle and models above 30 tonne are supplied with a handle for the carrying. A wiper seal is fitted on models above 5 tonne to prevent the penetration of dirt and to extend the life of the cylinder.

#### STANDARD

- Base mounting **holes**.
- **Pushing saddle** prevents any risk of rod deformation.

#### ACCESSORIES

- **ZTT tilt saddle** reduces the effects of any possible off-centred load.
- **Base plates ZAB**.
- **Clevis eyes. ZAR and ZAE**.

#### OPERATIONAL AREAS

These cylinders can be operated in any position and are extremely versatile and suitable for different applications, including industrial works, steel structural works, presses and special applications.

The nitride treatment gives these cylinders an excellent resistance to corrosion and makes them particularly suitable to operate in the open air or in aggressive environments.



#### ACCESSORIES ZTT TILT SADDLES

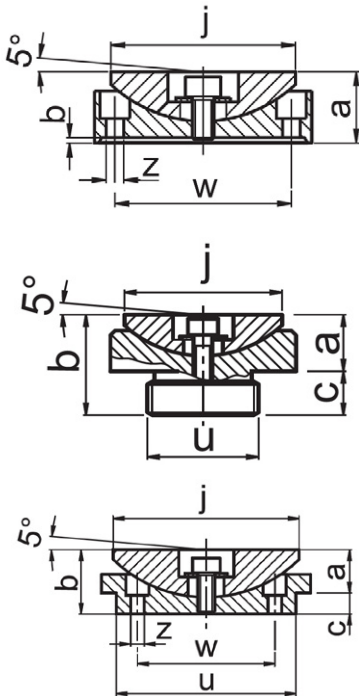

MODEL	For use with	a mm	b mm	c mm	j mm	u mm	z mm	w mm	kg
ZTT10	CMI10N25	16	1	-	34	-	5.5	24	0.1
ZTT11	CMI10N # # #	9	21	12	34	M24x2	-	-	0.1
ZTT11W	CMI10W # # #	9	21	12	34	1" - 8	-	-	0.1
ZTT31	CMI25N # # #	16	30	14	53	M32x2	-	-	0.3
	CMI30N210								
ZTT31W	CMI25W # # #	16	30	14	53	1 1/2" - 16	-	-	0.3
ZTT51	CMI50 # # # #	18	26	8	68	65	5.5	45	0.8
ZTT101	CMI100 # # # #	22	32	10	88	85	6.5	65	1.6

The **CMI#W** cylinder version can be purchased starting from a minimum of 10 pieces.



It's important to drop the pressure inside the cylinder before disconnecting the quick coupler to avoid problems if re-inserting or lowering the load. In case some pressure persists it is possible to use the apposite tool **KST38** in order to lower the pressure in the couplers.



To operate with these cylinders the **MD** power units are particularly suitable.

# CMI#N / CMI#W

## MULTI-PURPOSE CYLINDERS SPRING RETURN WITH IMPERIAL THREAD

### ACCESSORIES ZAB BASE PLATES

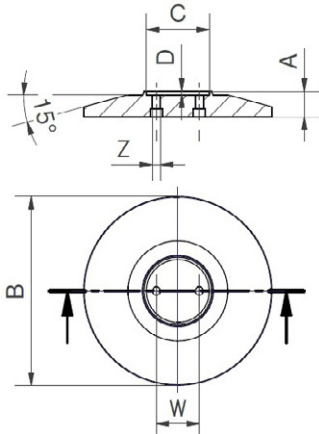

MODEL	For use with	A mm	B mm	C mm	D mm	Z mm	W mm	kg
ZAB5	CMI5N ###	35	215	40	5	7	25	6.4
	CMI5W ###							
ZAB10	CMI10N ###	35	235	60	5	9	39	7.9
	CMI10W ###							
ZAB25	CMI25N ###	35	255	85	5	11	58	9.5
	CMI25W ###							

### ACCESSORIES ZAR BASE CLEVIS EYES

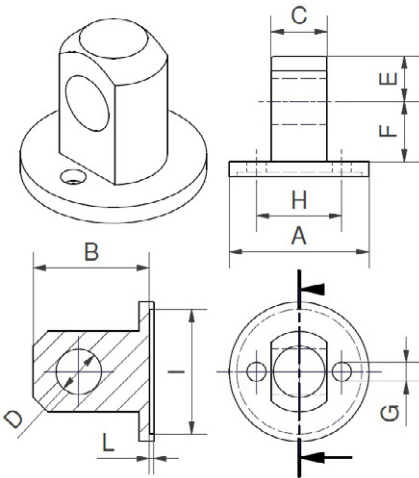

MODEL	For use with	A mm	B mm	C mm	D mm	E mm	F mm	G mm	H mm	I mm	L mm	kg
ZAR5	CMI5N ###	Ø45	47	14	Ø16	16	25	Ø7	Ø25	Ø40	4	0.2
ZAR10	CMI10N ###	Ø65	66	25	Ø22	25	35	Ø8,5	Ø39	Ø60	4	0.6
ZAR25	CMI25N ###	Ø95	79	38	Ø31	31	41	Ø13	Ø58	Ø85	3	1.3
ZAR5W	CMI5W ###	Ø45	47	14	Ø16	16	25	Ø7	Ø25	Ø38	4	0.2
ZAR10W	CMI10W ###	Ø65	66	25	Ø22	25	35	Ø8,5	Ø39	Ø57	4	0.6
ZAR25W	CMI25W ###	Ø95	79	38	Ø31	31	41	Ø13	Ø58	Ø84	3	1.3

### ACCESSORIES ZAE#M PLUNGER CLEVIS EYES

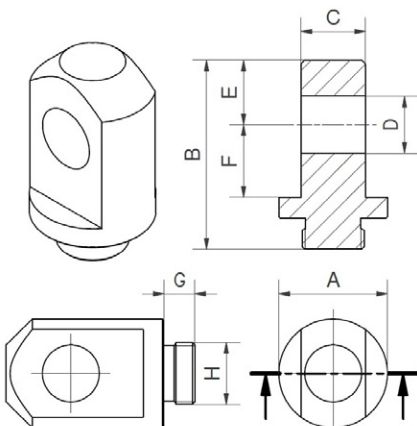

MODEL	For use with	A mm	B mm	C mm	D mm	E mm	F mm	G mm	H mm	kg
ZAE5M	CMI5N ###	Ø28	55	14	Ø16	16	19	10	M16 x2	0.15
ZAE10M	CMI10N ###	Ø42	73	25	Ø22	25	28	12	M24 x2	0.45
ZAE25M	CMI25N ###	Ø57	85.5	38	Ø31	31	35	14.5	M32 x2	1
ZAE5MW	CMI5W ###	Ø28	55	14	Ø16	16	19	10	3/4" - 16	0.15
ZAE10MW	CMI10W ###	Ø42	73	25	Ø22	25	28	12	1" - 8	0.45
ZAE25MW	CMI25W ###	Ø57	85.5	38	Ø31	31	35	14.5	1 1/2" - 16	1

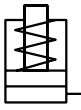

● FORCE	5 - 100 t
● STROKE	25 - 325 mm
● MAX WORKING PRESSURE	700 bar

# CMI#W

## MULTI-PURPOSE CYLINDERS, SPRING RETURN WITH IMPERIAL THREAD

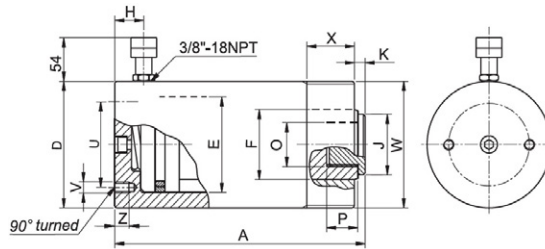

### SELECTION CHART

PUSHING FORCE t* kN	STROKE mm	EFFECTIVE AREA cm <sup>2</sup>	OIL VOLUME cm <sup>3</sup>	MODEL	CLOSED HEIGHT	Ø EXTERNAL	Ø PISTON	Ø ROD	COUPLER HEIGHT	Ø HOLLOW SADDLE	ROD PROJECTION	ROD INTERNAL THREAD	ROD THREAD DEPTH	PCD MOUNTING HOLES	MOUNTING HOLES DEPTH FOR I	COLLAR THREAD COLLAR LENGTH	WEIGHT
					A mm	D mm	E mm	F mm	H mm	J mm	K mm	O mm	P mm	U mm	V / Z mm	W / X mm	kg
5 43	25	6.1	15.5	CMI5W25	105	38	28	25	19	24.5	5	3/4" - 16	16	25	2xM6 10	1 1/2" - 16 28	1.1
	50		31	CMI5W50	130												1.3
	75		46	CMI5W75	155												1.5
	100		61.7	CMI5W100	180												1.7
	125		77	CMI5W125	205												1.9
	150		92.4	CMI5W150	230												2.1
10 97	25	13.9	34.7	CMI10W25	97	57	42	35	19	34	7	1" - 8	19	39	2xM8 12	2 1/4" - 14 28	2.2
	50		69.3	CMI10W50	122												2.7
	75		104	CMI10W75	147												3.2
	100		139	CMI10W100	172												3.7
	125		173.2	CMI10W125	197												4.2
	150		208	CMI10W150	222												4.7
15 149	25	21.2	53	CMI15W25	113	69	52	42	19	40	8	1" - 8	25	47	2xM8 12	2 3/4" - 16 30	3.3
	50		106.2	CMI15W50	138												3.8
	75		159.3	CMI15W75	163												4.4
	100		212.4	CMI15W100	188												5
	125		265.5	CMI15W125	238												5.6
	150		318.6	CMI15W150	263												6.3
	175		371.7	CMI15W175	288												7
	200		424.8	CMI15W200	313												7.6
25 232	25	33.4	83	CMI25W25	122	84	65	55	19	53	9	1 1/2" - 16	25	58	2xM10 14	35/16" - 12 49	5.1
	50		166	CMI25W50	147												5.7
	100		332	CMI25W100	217												7.7
	150		498	CMI25W150	267												9
	200		664	CMI25W200	317												10.4
	250		830	CMI25W250	367												11.8
	300		996	CMI25W300	417												13.1
50 496	50	70.9	354	CMI50W50	164	127	95	80	25	65	4	M16	12	95	2xM12 18	5" - 12 55	14.2
	100		709	CMI50W100	214												17.4
	150		1063	CMI50W150	264												20.8
	325		2304	CMI50W325	439												32.6
100 929	100	132.7	1327	CMI100W100	246	175	130	100	26	85	4	M16	17	140	2xM12 18	6 7/8" - 12 65	39.6
	150		1991	CMI100W150	296												46

The CMI#W cylinder version can be purchased starting from a minimum of 10 pieces.

\* Nominal value, see kN for the exact force.