

• RESERVOIR CAPACITY	10 l
• DELIVERY AT 700 BAR	0,6 l/min
• MAX PRESSURE	700 bar
• POWER RATING	1,5 kW

MBE BATTERY PUMP

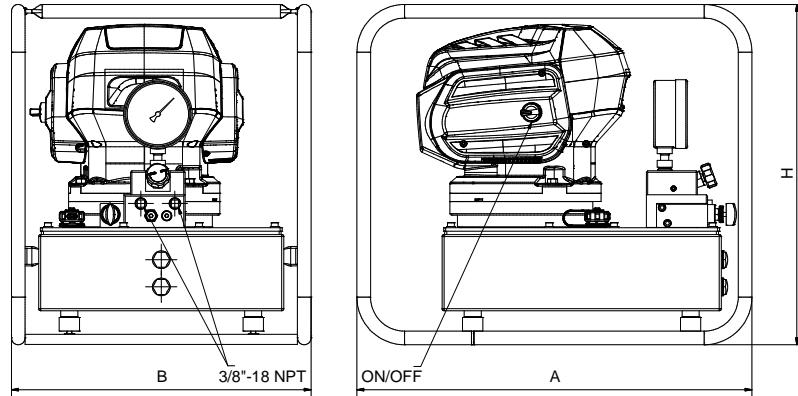

HYDRAULIC PUMPS

FEATURES

This pump is structured with the highest technology carefully studied to ensure longevity, the best performance and reliability and exceptional handiness.

The axial piston pump generates a maximum working pressure of 700 bar with an oil flow of 0,6 l per minute. The pump is equipped with a low pressure stage set at 85 bar with an oil flow of 6,0 l per minute to quickly fill in the circuit or to quickly approach the cylinder to the load.

The pump is fitted with a 10 liter low tank, transport handles for the standard version, protective and transport cage for the C version, manual position or spring centered valves, ON/OFF switch button.

OPERATIONAL CHARACTERISTICS

MODEL	OIL DELIVERY		PRESSURE		MOTOR			BATTERY *		
	1° Stage	2° Stage	1° Stage	2° Stage	Voltage	Power	Speed	Tension	Capacity	Duration **
	l/min	l/min	bar	bar	V	kW	npm	V	Ah	Min
MBE11	6,0	0,6	85	700	82	1,5	2200	82	8	15 ÷ 25

* Not included, it can be added upon request

** Discontinuous, it can vary depending on the conditions and the pressure.

MBE

BATTERY PUMP

FEATURES

The functioning is smart, quick and practical thanks to the **ON/OFF** motor switch button positioned on the left side of the pump. The power pack can be equipped with different manual valves (3/2 handwheel valve, 3/3-4/3 manual position or spring centered valves) positioned over the **3/8"-18 NPT** exits.

The standard pump is equipped with:

- The 82 V 1500 W electric motor pump which can be used with an extractable battery, external ON/OFF switch and internal security key.
- High pressure axial piston pump.
- Base plate useful to house different manual valves.
- 10 - 20 - 40 liter reservoir.
- Protection and transport cage.
- Two position filler and briefing cap.

SIZE TABLE

MODEL	Oil volume reservoir	Oil volume usable	Dimensions mm			Weight ***
	litres	litres	A	B	H	Kg
MBE11###	10	7.0	480	390	430	43
MBE11###C			620	450	500	46

*** Including oil, excluding battery

The 82 V 8 Ah battery and the quick battery charger are equipped separately, they are not included with the power pack.