

• RESERVOIR CAPACITY	11 l
• DELIVERY AT 700 bar	0,21 l min
• POWER RATING	0,25 kW
• MAX PRESSURE	700 bar

MC

MICRO HYDRAULIC POWER PACKS / 700 bar

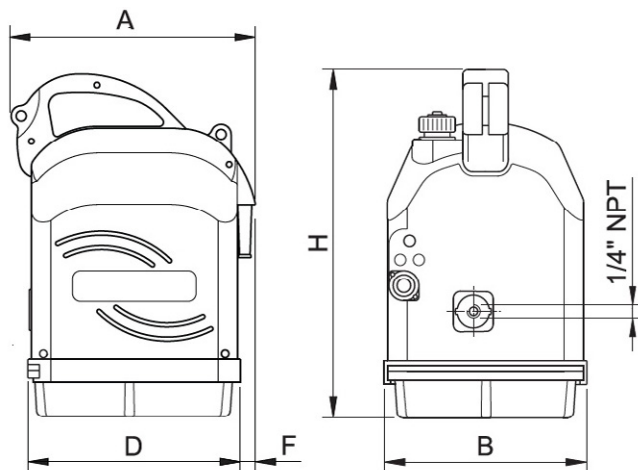

HYDRAULIC PUMPS

SELECTION CHART

MAXIMUM PRESSURE	DELIVERY AT MINIMUM PRESSURE	DELIVERY AT MAXIMUM PRESSURE	RESERVOIR CAPACITY	USABLE OIL VOLUME	MODEL	DIMENSIONS MM					WEIGHT
						A	B	D	F	H	
bar	l/min	l/min	litres	litres							
700	0.32	0.21	1	0.8	MC71	245	197	212	15	345	9
					MC72						
					MC73						

FUNCTION CHART

MODEL	For use with	Remote control function	SYMBOL
MC71	Single acting	Advance - Return (1 push button)	
MC72		Advance - Hold - Return (2 push buttons)	
MC73		Advance - Return (integrated control located at the end of the hose assembly - 1 push button)	

MODEL CODING

MC	7	#
Series	Pressure setting	Control type