

MDW

700 bar HYDRAULIC POWER
PACKS FOR TORQUE WRENCHES
OF SMALL AND MEDIUM CAPACITY

	• RESERVOIR CAPACITY	2,6 l
	• DELIVERY AT 700 BAR	0,4 - 6,0 l/min
	• POWER RATING	0,75 - 1,5 kW
	• AIR CONSUMPTION	2130 l/min
	• MAX PRESSURE	700 bar

For big capacity torque wrenches check models MEE10WR/4, MME10WR/4 e MPE10WR/4

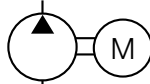
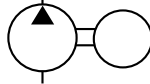
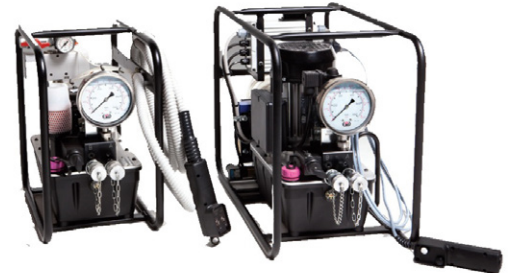
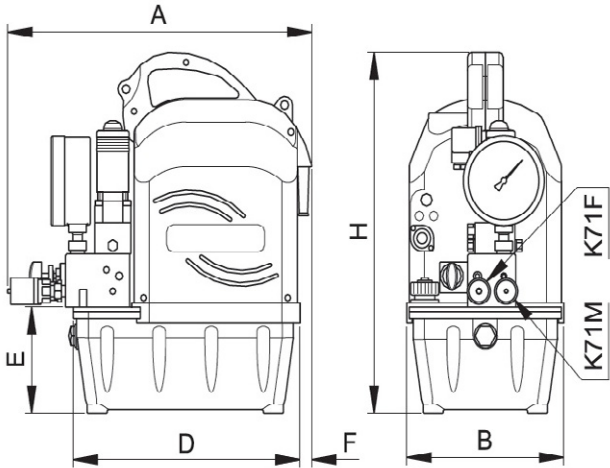

SELECTION CHART

MODEL	OIL DELIVERY		PRESSURE		MOTOR		
	1°Stage	2°Stage	1°Stage	2°Stage	Power supply	Power	Speed
	l/min	l/min	bar	bar		kW	rpm/min
MDWR	2.4	0.4	65	700	230V - 50 Hz	0.75	2800
MDWRH	6	0.6				1.1	
MDWRP					Air	1.5	
MDWRHE					230V - 50 Hz	1.1	

DIMENSIONS CHART

MODEL	RESERVOIR CAPACITY	USABLE OIL VOLUME	DIMENSIONS MM						WEIGHT
	litres	litres	A	B	D	E	F	H	kg
MDWR	2.6	2.4	381	197	287	119	15	406	18.5
MDWRH			400	250	-	-	-	420	23.8
MDWRP			380	230	-	-	-	390	17.5
MDWRHE			540	285	540	119	-	420	30.3

FUNCTION CHART

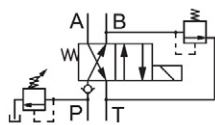
MODEL	FOR USE WITH	VALVE FUNCION	SYMBOL
MDWR	Torque wrenches	Advance-return	
MDWRH			
MDWRP			
MDWRHE			