

ME

MODULAR POWER PACKS WITH 3-PHASE ELECTRIC MOTOR

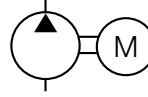

• RESERVOIR CAPACITY	5 - 60 l
• DELIVERY AT 700 BAR	0,45 - 2,5 l/min
• POWER RATING	0,75 - 3 kW
• MAX PRESSURE	700 bar

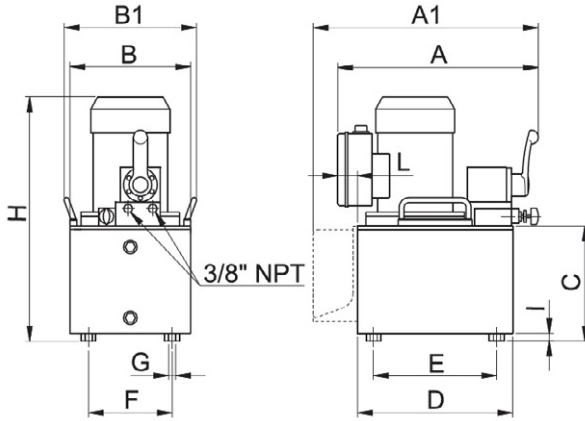

SELECTION CHART

Reservoir capacity litres	Usable oil volume litres	Dimensions mm													
		A	A1 (2)	B	B1	C	D	E	F	G	H (1)	I	L		
5	3.5	370	470	245	270	129	315	250	170	M8	390	10	40		
10 high	9					227					488				
10 low	7					378					390				
20	17.5	447	-	360	-	129	410	320	270	Ø9	518	40	-		
40	34	440				257					320			270	622
60	60	457				440					350			510	660
MEK 30	30	440	-	360	-	362	410	320	270	Ø9	685	40	-		
MEV 30	18.5										660				
MEK 50	54										685				
MEV 50	33	457	-	600	-	362	440	350	510	Ø9	660	40	-		

1) Add 16 mm for models **MEC, MEH, MED, MEE**.
Add 44 mm for models **MEL, MEF, MEG, MET**.

2) Only for power packs with 5 litres and 10 litres high tank with remote control model **R** or **F**.

OPERATIONAL CHARACTERISTICS

MODEL	OIL DELIVERY		PRESSURE		MOTOR		
	1°Stage	2°Stage	1°Stage	2°Stage	Voltage	Power	Speed
	l/min	l/min	bar	bar		kW	rpm/min
MEA	0.9	0.45	100	700	400V - 50 Hz (motors with different voltage upon request)	0.75	1400
MEB	4.7		85				
MEC	-		-				
MED	1.8	0.9	100			1.1	2800
MEH	2.4	85					
MEE	9.4	70					
MEL	-	1.6	-			2.2	1400
MEK	10.6	70					
MEF	-	-					
MEG	4.7	1.8	85			3	2800
MET	10	85					
MEV	10	2.5	1400				



MEK power packs are particularly indicated for intensive use or if a silent product is required.

