

ME-PP / MM-PP

MODULAR POWER PACKS FOR GEOTECHNICAL STRUCTURAL TESTS STANDARD VERSION

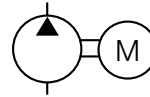

• RESERVOIR CAPACITY	10 - 40 l
• DELIVERY AT 700 BAR	0,9 l/min
• POWER RATING	1,1 - 1,5 kW
• MAX PRESSURE	700 bar

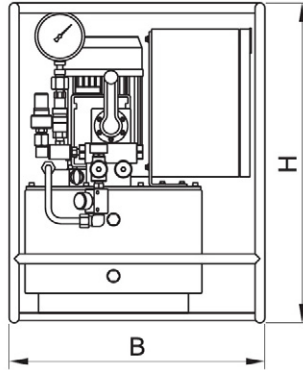
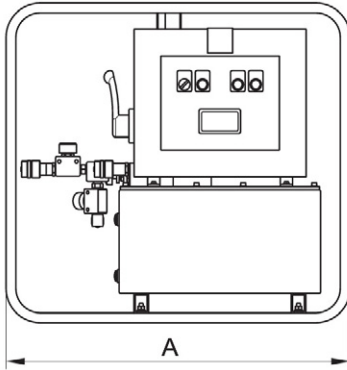

FEATURES

Many years of experience in the geotechnical field, in particular test piles, have enabled EUROPRESS to develop a complete product with special features answering the demands of this industry.

The main features of the power pack, the core of the system are:

- Digital display that can be set up on the desired pressure values.
- Automatic pressure reactivation (also in case of structural yieldness).
- Hysteresis cycle system settings.
- Automatic or manual control.
- Possibility to make test cycles by decreasing pressure.
- It can be used with single and double acting cylinders.
- External pressure setting (50-700 bar range).
- Single or 3-phase electric motor.
- Two stage pump 2,4/0,9 l/min at 1400 rpm.
- Manual 4 way 3 pos valve with pilot check.
- 10, 20 or 40 litres tank.
- Protective and transport cage.
- 100 mm diameter analogic gauge.

OPERATIONAL AREAS

Non destructive tests on concrete structures, tests on construction materials and geotechnical experiments both on site and in laboratories.

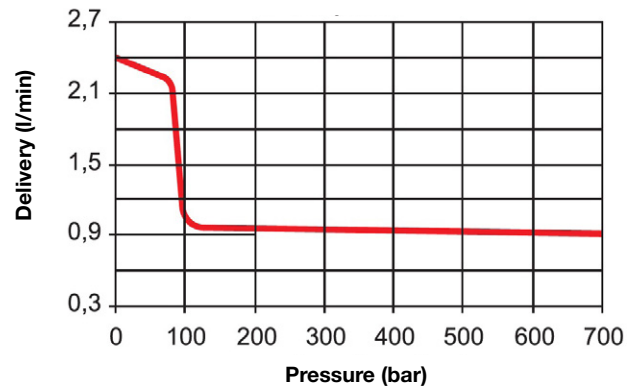

OPERATIONAL CHARACTERISTICS

MODEL	OIL DELIVERY		PRESSURE		MOTOR			RESERVOIR CAPACITY	USABLE OIL VOLUME	DIMENSIONS MM		
	1°Stage	2°Stage	1°Stage	2°Stage	Power supply	Power	Speed			A	B	H
	l/min	l/min	bar	bar		kW	rpm					
MEH11M52PP	2.4	0.9	85	700	400V - 50 Hz	1.1	1400	10	7.5	750	520	500
MEH20M52PP								20	17.5			650
MEH40M52PP								40	34			780
MMH11M52PP					230V - 50 Hz	1.5		10	7.5			500
MMH20M52PP								20	17.5			650
MMH40M52PP								40	34			780

ME-PP / MM-PP

MODULAR POWER PACKS FOR GEOTECHNICAL STRUCTURAL TEST ADVANCED VERSION

ME-PP3 / MM-PP3

FEATURES

These power packs have the same characteristics and ancillaries as the standard base version except for **the 4 channel digital screen** (1 pressure + 3 stroke positions). The operator has the possibility to keep under control in real time 4 different signals.

These power packs can be connected directly to the PC thanks to an USB port. This function is useful to download the information obtained from the tests.

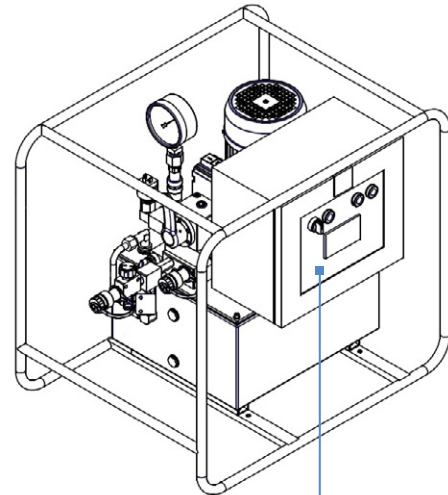

DIGITAL 4 CHANNEL
INDICATOR

ME-PPD / MM-PPD

FEATURES

These power packs have **the most advanced technology regarding geotechnical tests**. They have the same characteristics and ancillaries as the standard versions but they have the freedom to check and customize all the functioning parameters and automatic work instructions; all these features make the -D version particularly suitable for the experts of this industry.

The main features are:

- HMI 10.1" touch screen display.
- Real time 4 signal visualisation (1 pressure + 3 stroke positions).
- Free planning of lifting / lowering at different pressures.
- Free planning of goal reaching / pressure maintaining.
- → **P(t) can be defined by the operator.**
- Visualize final graphics.
- Allows the direct connection to the PC through a USB port which is useful to download the information of the tests accomplished in CSV format (M.Excel) (pressure, movements, time, average movements and other parameters are available on request).

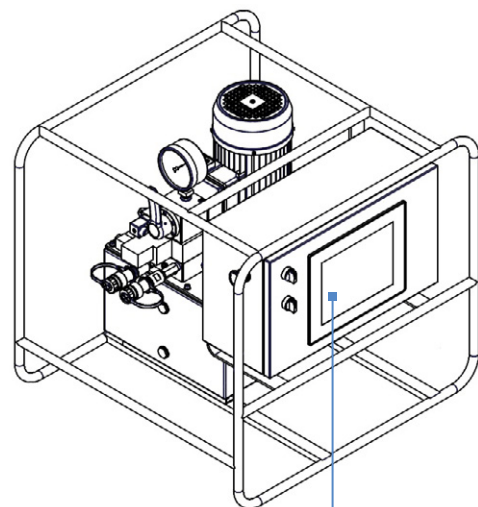

DISPLAY HMI
TOUCHSCREEN 10.1"