

# MM

## MODULAR POWER PACKS WITH SINGLE PHASE ELECTRIC MOTOR

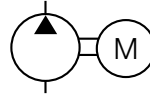

• RESERVOIR CAPACITY	5 - 60 l
• DELIVERY AT 700 BAR	0,45 - 0,9 l/min
• POWER RATING	0,75 - 1,5 kW
• MAX PRESSURE	700 bar

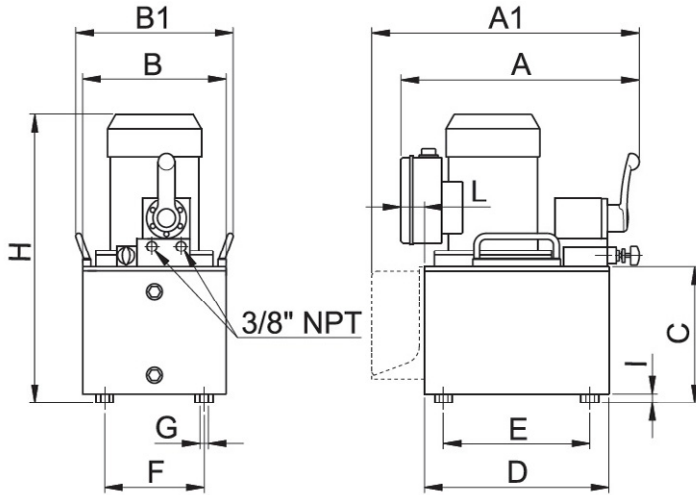

### SELECTION CHART

RESERVOIR CAPACITY	USABLE OIL VOLUME	DIMENSIONS MM											
		A	A1 (2)	B	B1	C	D	E	F	G	H (1)	I	
litres	litres												
5	3.8	370	470	245	270	129	315	250	170	M8	410	10	
10 high	8.8					227					508		
10 low	7.7	447		360	378	129	410	320	270	Ø9	410	40	
20	17.7					257					538		
40	35.8	440		600		362	440	350	510		642		
60	51					362					642		

1) Add 48 mm for models **MMC**, **MMH**.

2) Only for 5 litres and 10 litres high tanks with remote control model **R** or **F**.

### OPERATIONAL CHARACTERISTICS

MODEL	OIL DELIVERY		PRESSURE		MOTOR		
	1°Stage	2°Stage	1°Stage	2°Stage	Power supply	Power	Speed
	l/min	l/min	bar	bar			
<b>MMA</b>	0.9	0.45	100	700	230V - 50 Hz (motors with different voltage upon request)	0.75	1400
<b>MMB</b>	4.7		85				
<b>MMC (1)</b>	-	-					
<b>MMD</b>	1.8	0.9	100				
<b>MMH (1)</b>	2.4		85				
<b>MME</b>	9.4		85				

### DELIVERY DIAGRAM

