

• RESERVOIR CAPACITY	5 - 40 l
• DELIVERY AT 700 BAR	0,9 l/min
• POWER RATING	2,6 kW
• MAX PRESSURE	700 bar
• CONSUMPTION	3400 l/min

MP

MODULAR POWER PACKS WITH AIR MOTOR

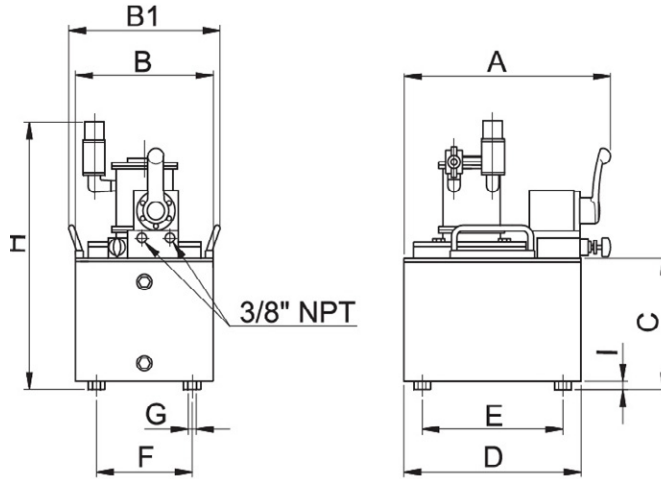

HYDRAULIC PUMPS

DIMENSIONS CHART

Reservoir capacity	Usable oil volume	Dimensions mm											
		A	A1	B	B1	C	D	E	F	G	H ①	I	
litres	litres												
5	3.5	370	470	245	270	129	315	250	170	M8	390	10	
10 high	9					227					488		
10 low	7.5	447	-	360	378	410	320	270	Ø9	390			
20	17.5				257					518			
40	34				362					622			

OPERATIONAL CHARACTERISTICS

MODEL	OIL DELIVERY		PRESSURE		MOTOR	
	1°Stage	2°Stage	1°Stage	2°Stage	Power	Speed
	l/min	l/min	bar	bar	kW	rpm/min
MPD	1.8	0.9	100	700	2.6	3000
MPE	9.4		85			

DELIVERY DIAGRAM

PUMPS D

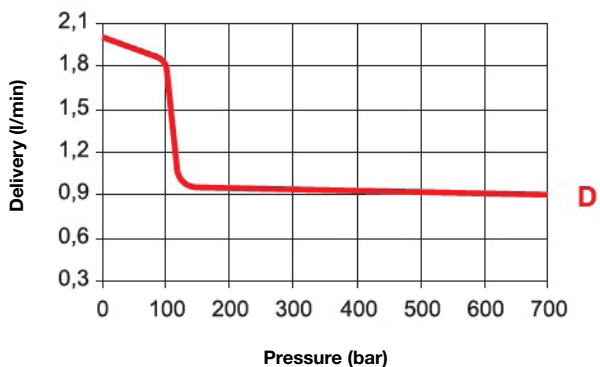

PUMPS E

