

MS

MODULAR POWER PACKS WITH PETROL ENGINE

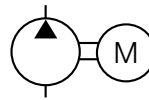

• RESERVOIR CAPACITY	10 - 40 l
• DELIVERY AT 700 BAR	0,9 - 1,8 l/min
• POWER RATING	4,4 HP - 3,3 CV
• MAX PRESSURE	700 bar
• CONSUMPTION	1,2 l/h with full load 0,9 l/h at 75% capacity

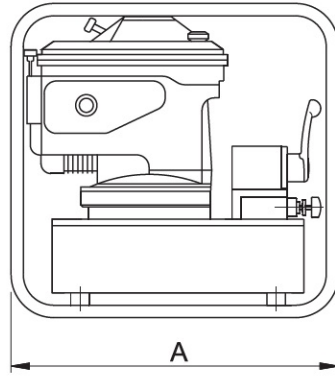
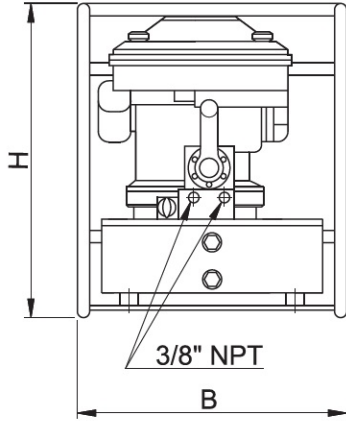

DIMENSIONS CHART

Reservoir capacity		Usable oil volume	Dimensions mm		
litres		litres	A	B	H
10 low		7.5	620	450	500
20		17.5			650
40		34			780

OPERATIONAL CHARACTERISTICS

MODEL	OIL DELIVERY		PRESSURE		MOTOR	
	1°Stage	2°Stage	1°Stage	2°Stage	Power	Speed
	l/min	l/min	bar	bar	kW	rpm/min
MSD	1.8	0.9	100	700	4,4 HP - 3,3 kW	3000
MSE	9.4		85			
MSF	-	1.8	-			
MSG	4.7		85			

DELIVERY DIAGRAM

