

# UMB

## HYDRAULIC BOTTLE JACKS

• FORCE	3 - 50 t
• STROKE	105 - 150 mm

### FEATURES

UMB bottle jacks are made up of a single base, cylinder, reservoir and pump unit. All jacks are supplied with an operating lever. 25, 30 and 50 tonne models have a carry handle for ease of transport. All models can be used horizontally with the pumping unit below the cylinder. The seals are easily replaced cutting service time down to the minimum. Jacks are fitted with a stroke limiting device and safety valves.

### OPERATIONAL AREAS

These jacks are ideal for a variety of lifting or pushing jobs and can be used in many different industries.



Products subject to periodic variations. For more detailed information please call the sales department or visit our website.

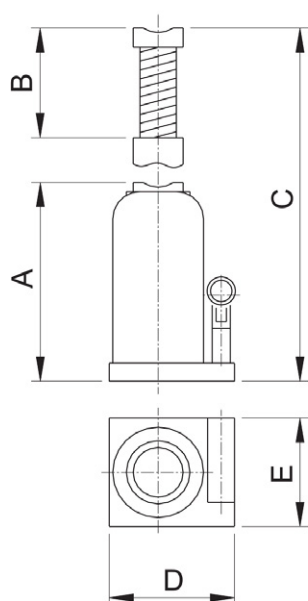

### SELECTION CHART

FORCE T	STROKE mm	MODEL	DIMENSIONS MM					WEIGHT kg	
			A	B	C	D	E		
3	105	UMB3N105	168	65	338	117	75	24	3,7
3	150	UMB3N150	210		425	117	75	24	4
5		UMB5N150	212		437	125	75	29	4,5
8		UMB8N150	219		444	144	90	38	6,3
10		UMB10N150	219	444	144	90	38	6,5	
12		UMB12N150	226	75	451	165	110	45	8,5
15		UMB15N150	228		453	165	110	45	9
20	UMB20N150	234	459		173	120	61	11	
25	UMB25N150	242	467		196	144	69	15,5	
30	UMB30N150	242	467	196	144	69	15,5		
50	140	UMB50N140	260	-	400	214	165	80	27